

Lipid Biosynthesis



Craig Wheelock

February 2nd, 2009

Questions? Comments? craig.wheelock@ki.se

Why do we care about lipids?

- ~80% of European population overweight
- ~ 1/3 obese
 - =130 million obese adults in EU
 - 6% of total health costs
 - 10-13% of deaths in Europe

Contributes to diabetes, coronary heart disease, hypertension, stroke & cancer

Diseases of dyslipidemia are one of the greatest health challenges of the 21st century

Outline

- **Lipid overview: synthesis and structure**
- **Fatty acids**
- **Eicosanoids**
- **Break**
- **Triacylglycerols**
- **Phospholipids**
- **Cholesterol**
- **Bile acids, enterohepatic circulation**
- **Summary**

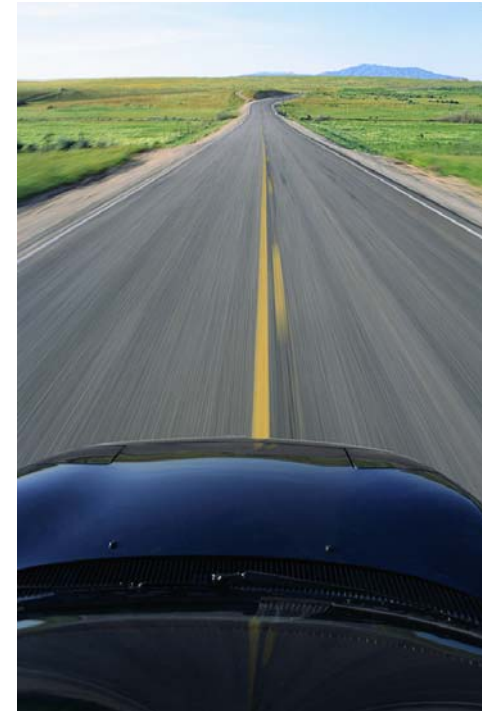

What is a lipid?

Classical definition:

biological molecule that is soluble in organic solvent,
but insoluble in water

Modern (specific) definition:

fatty acids and their derivatives, and substances related
biosynthetically or functionally to these compounds

More specific definition:

Hydrophobic small molecules that originate by carbanion-
based condensations of thioesters (fatty acids, polyketides,
etc.) and/or by carbocation-based condensations of isoprene
units (prenols, sterols, etc)

Vary greatly in structure and function

Some typical lipids

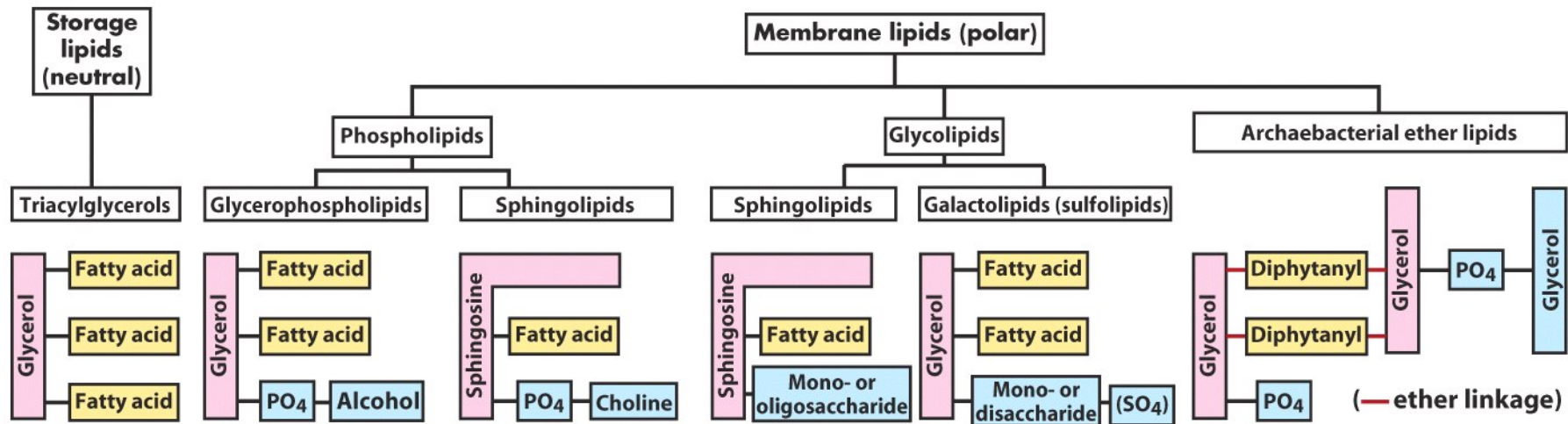

**In addition:
cholesterol, cofactors, vitamins, bile acids,
hormones, eicosanoids, other signaling
molecules, etc.....**

Varying Lipid Class

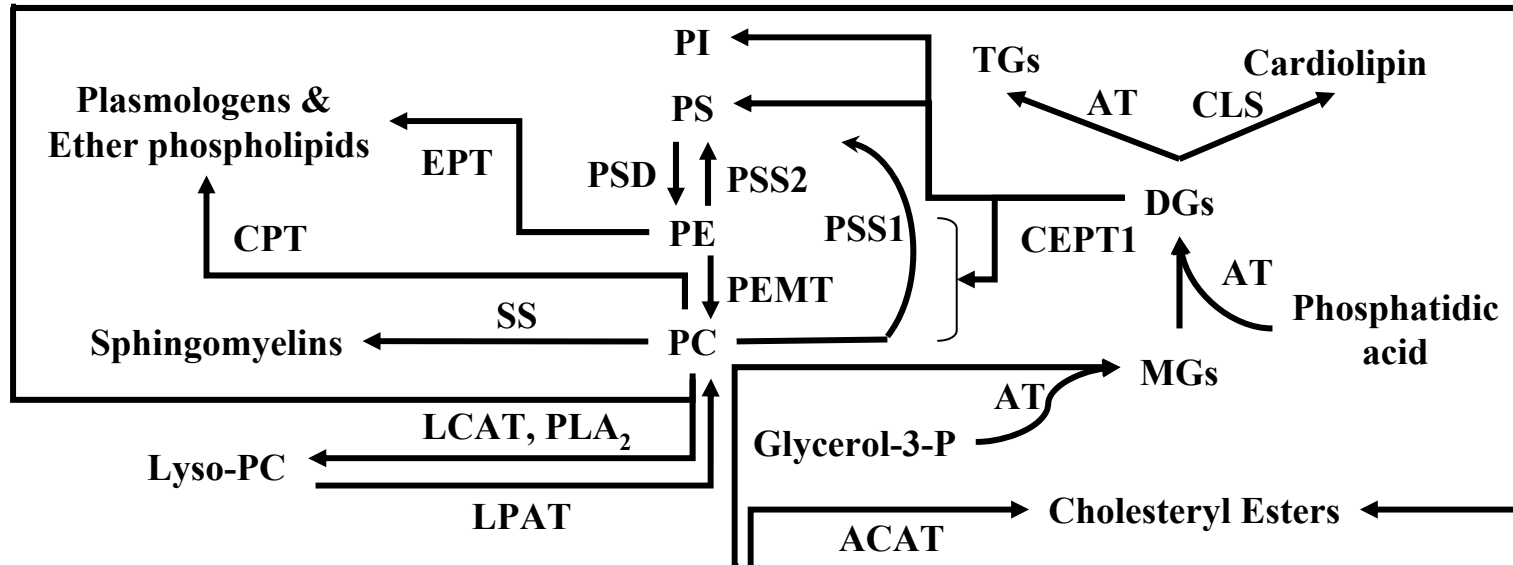

Free Fatty Acids

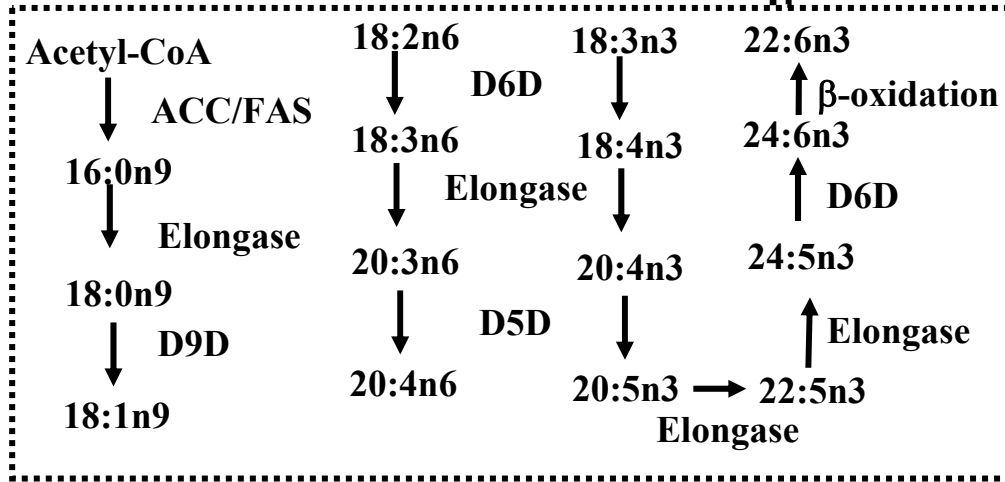

- EPT = ethanolamine-phosphotransferase
- CEPT1 = choline/EPT-1
- AT = acyltransferase
- LCAT = lecithin cholesterol AT
- ACAT = acyl coenzyme-A:cholesterol transferase
- LPAT = Lyso-PC AT
- PEMT = PE methyl transferase
- PSD = PS decarboxylase
- PSS = PS synthase
- CLS = cardiolipin synthase
- SS = sphingomelin synthase
- ACC/FAS=acetyl-CoA carboxylase
- FAS = fatty acid synthase

- PC = phosphatidyl choline
- PE = phosphatidyl ethanolamine
- PS = phosphatidyl serine
- PI = phosphatidyl inositol
- MGs = monoacylglycerols
- DGs = diacylglycerols
- TGs = triacylglycerols

Fatty acids (FA)

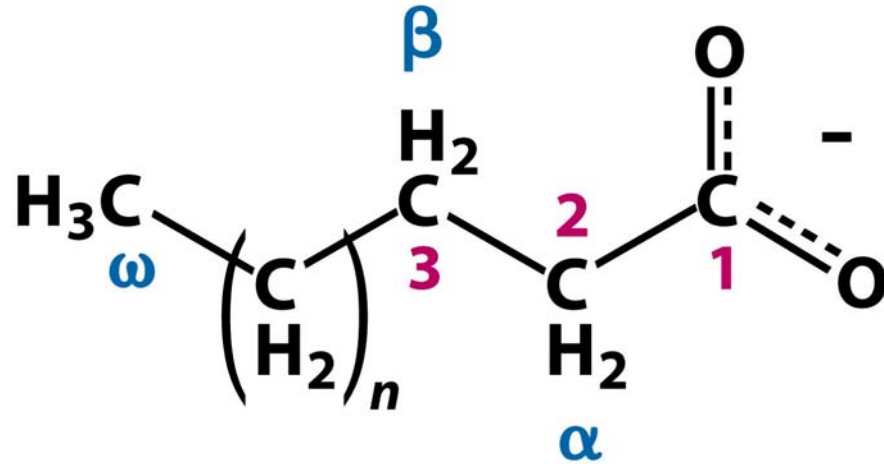

- compounds synthesized in nature via condensation of malonyl coenzyme A units by a fatty acid synthase complex
- contain even numbers of carbon atoms in straight chains (commonly C14- C24)
- may be saturated or unsaturated
- can contain variety of substituent groups

Fatty Acids

- Single(σ)-bonded carbon chains with a terminal carboxylic acid:



- Produced de novo by animals and plants
- Can contain double(π)-bonded carbons which are inserted by desaturases

Unsaturation & shorter chain

- ↓ melting point
- ↑ membrane fluidity (*cis* bond gives the "kink" in the carbon chain)

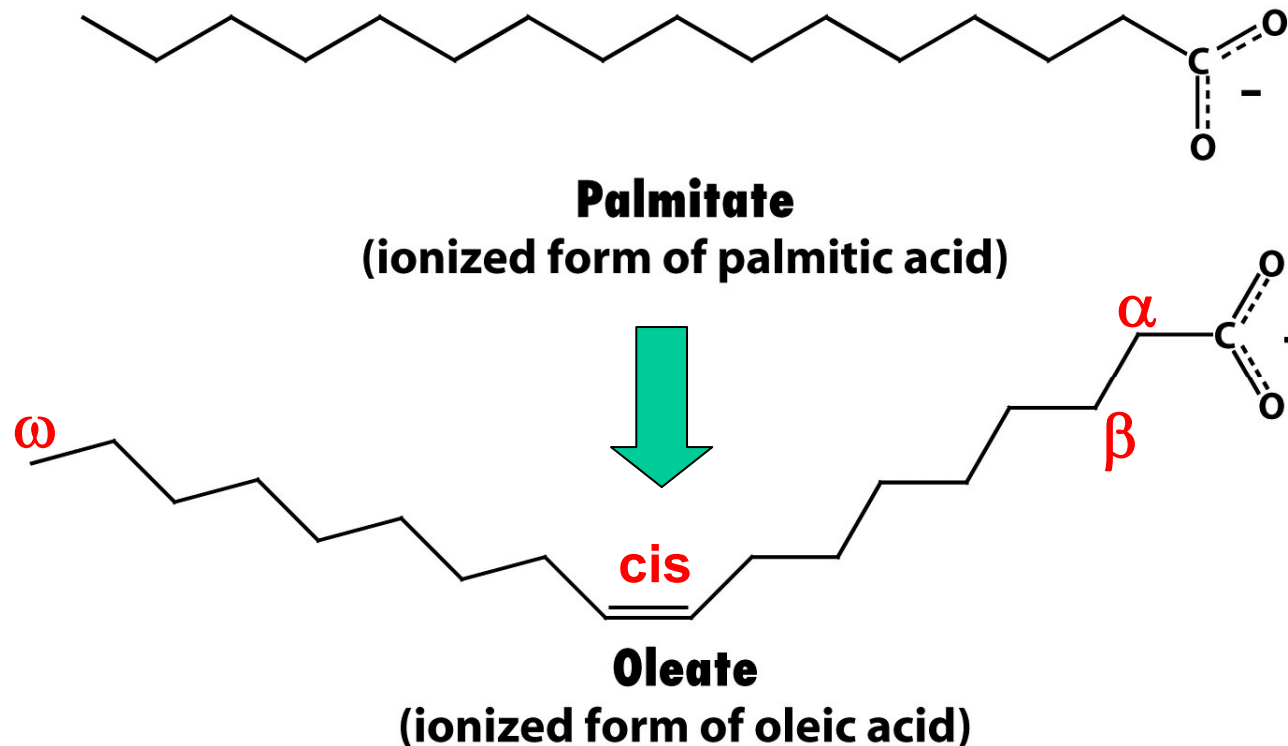

Nomenclature

- **Fatty acids are sigma-bonded carbon chains with a carboxylic acid functional group**



Nomenclature

- Individual fatty acids can be identified by one of two numerical nomenclature systems

n-Designation

Carbon numbering starts from methyl end

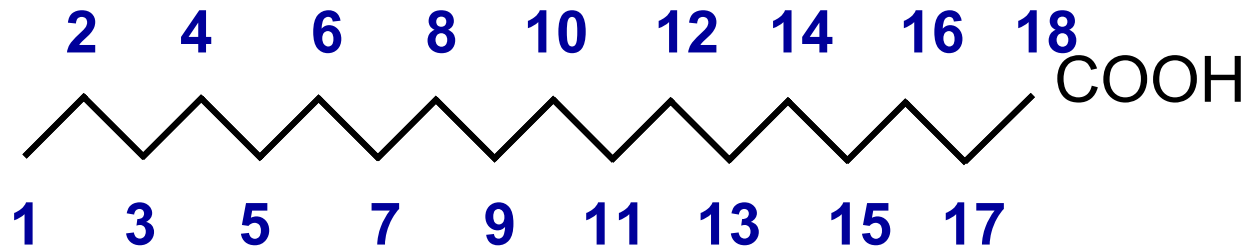

**stearic
acid
18:0**

Nomenclature

- Individual fatty acids can be identified by one of two numerical nomenclature systems

Δ -Designation

Carbon numbering starts from carboxyl group

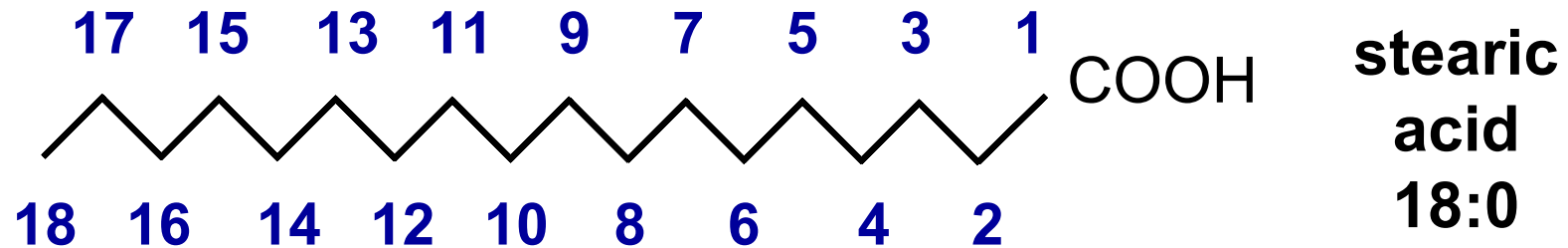

Nomenclature

- Standard nomenclature (arachidonic acid):

20:4 n6

n-Designation

Carb	Num	Position of double bonds
------	-----	--------------------------

20:4 Δ 5,8,11,14

Δ -Designation

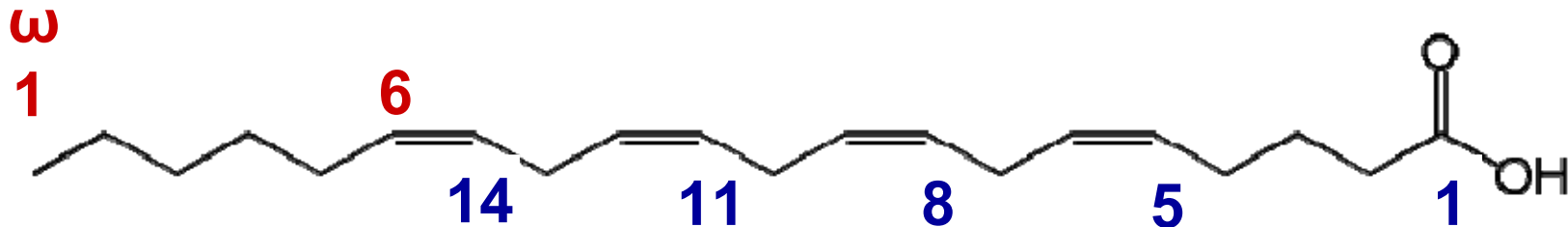

Desaturation of Fatty Acids

complex of 3 membrane proteins in E.R.

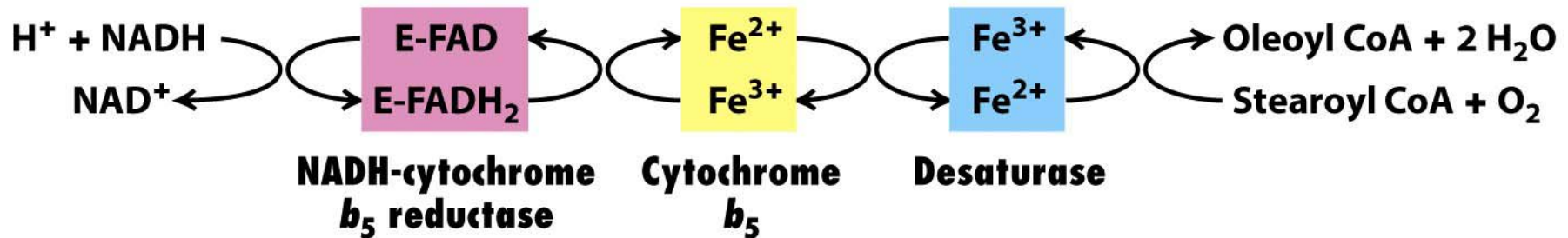

series of desaturase enzymes creates position-specific double bonds

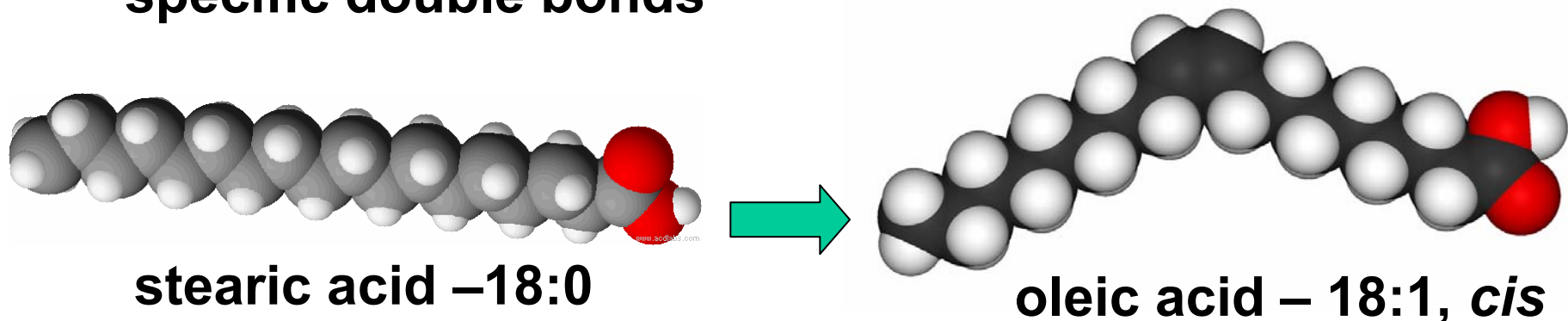

Fatty Acid Metabolism

- The first desaturation of a saturated fatty acid is always at the $\Delta 9$ position

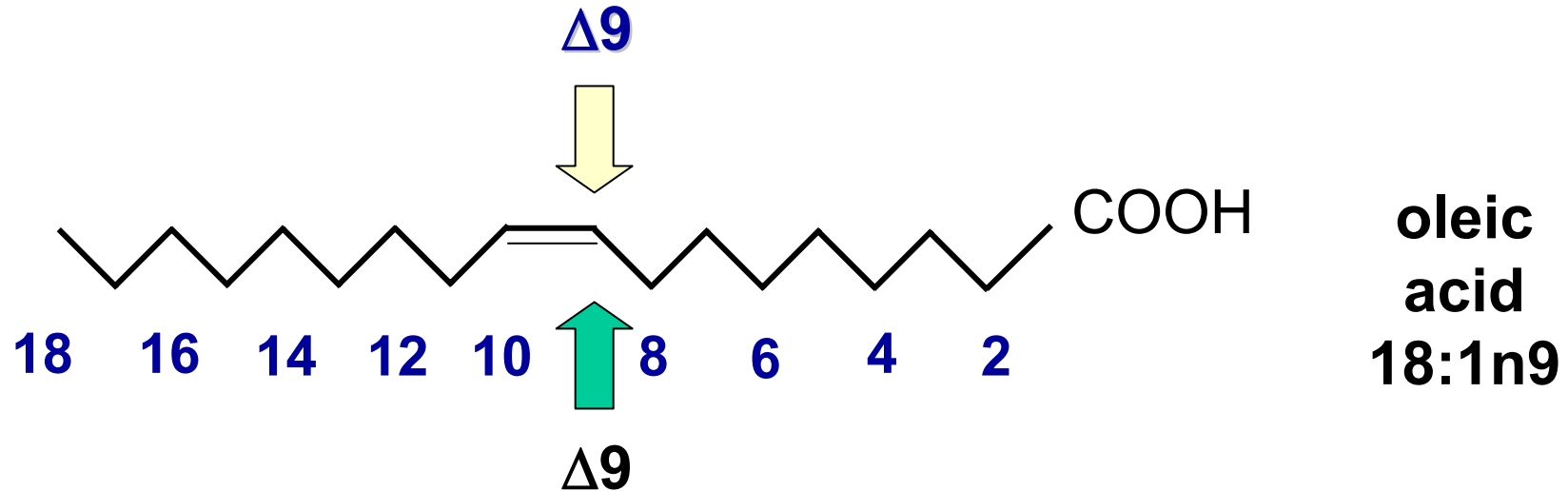

Fatty Acid Metabolism

- Plants can also desaturate at the $\Delta 12$

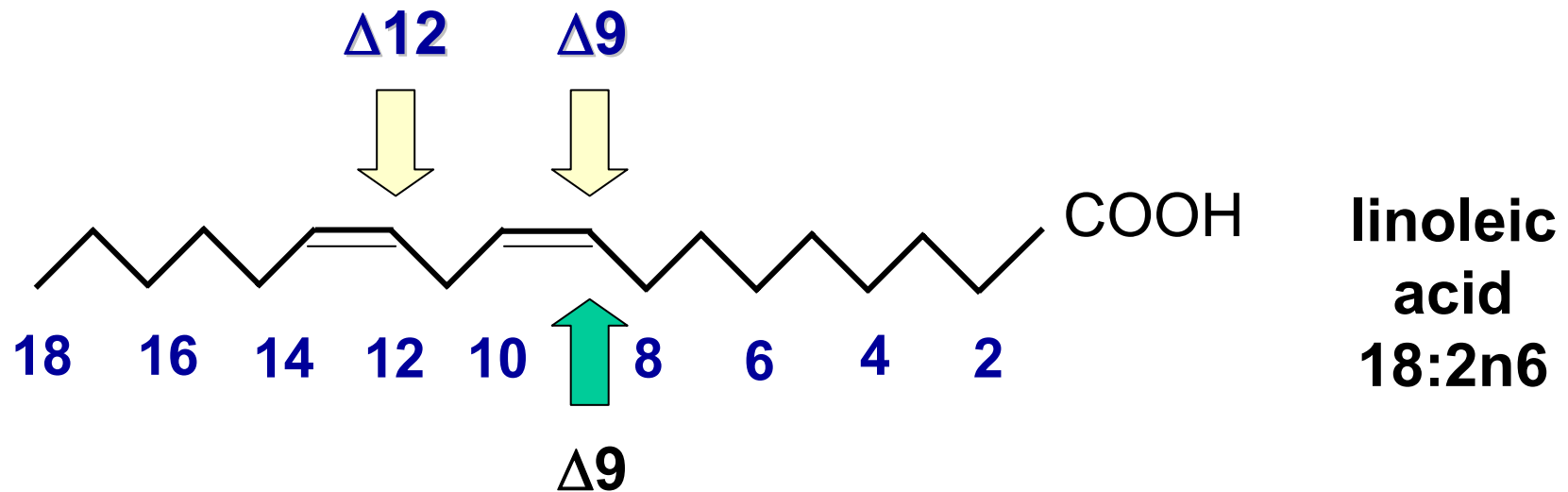

Fatty Acid Metabolism

- Plants can also desaturate at the $\Delta 12$ and the $\Delta 15$ carbon

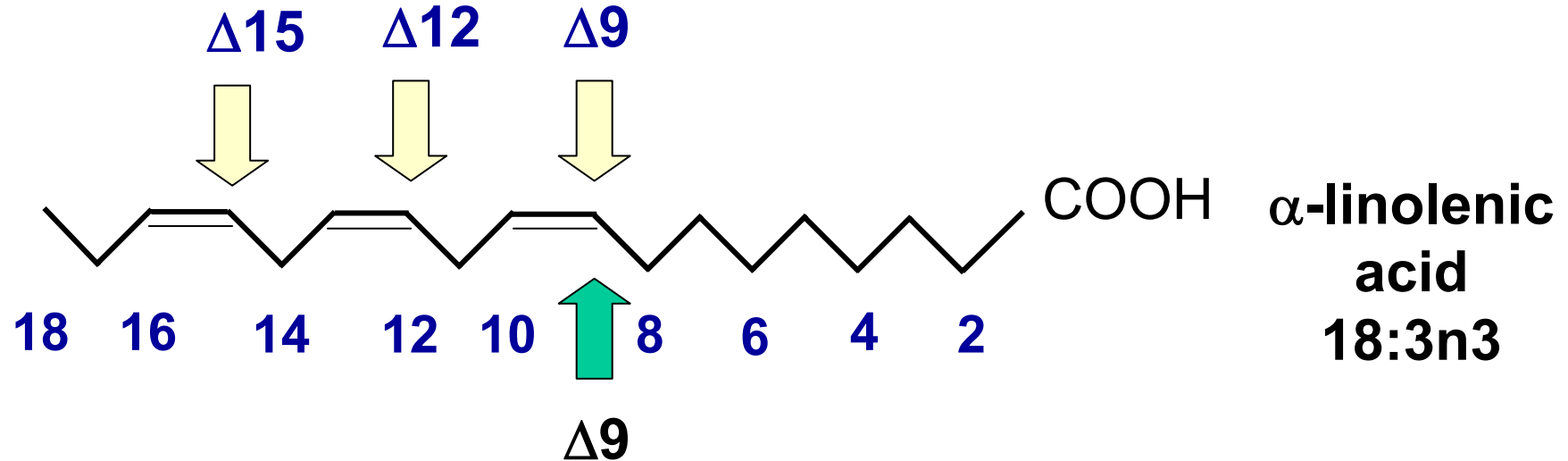

Fatty Acid Metabolism

- Animals desaturate plant-derived polyunsaturated fatty acids (PUFAs) at the $\Delta 6$ carbon

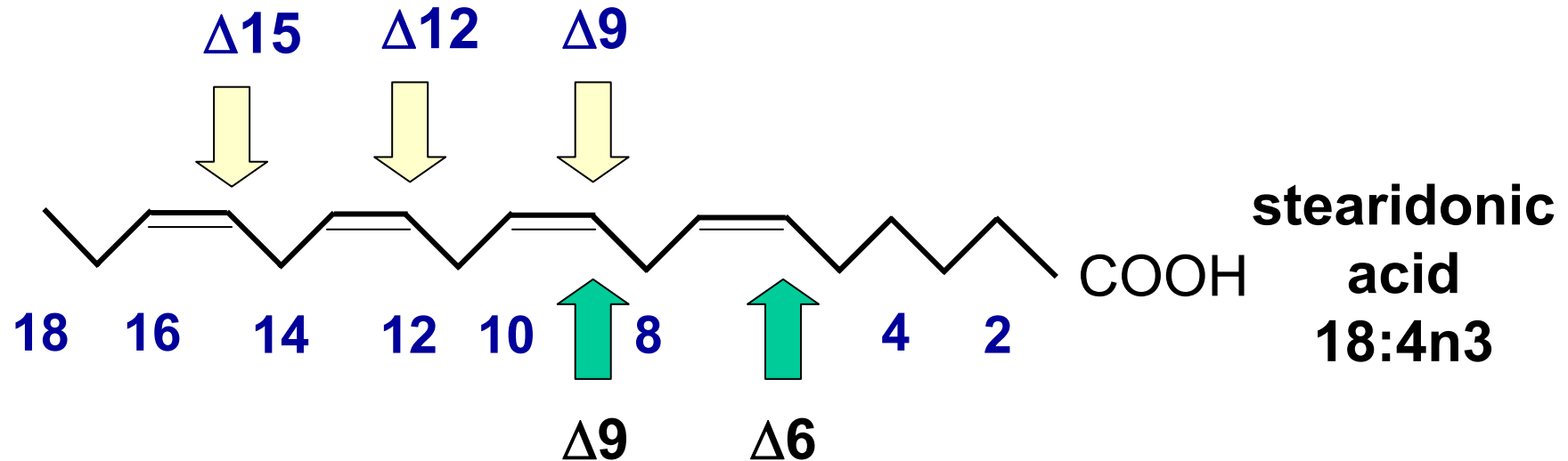

Fatty Acid Metabolism

- To add another double bond, animals must first elongate the fatty acid

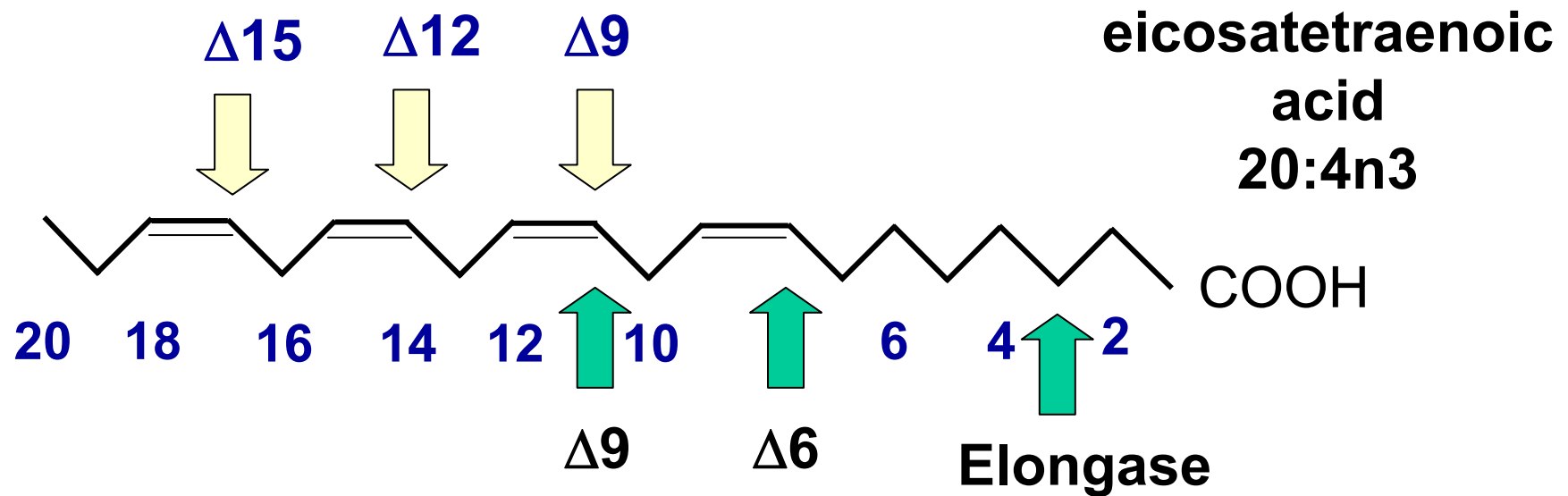

Fatty Acid Metabolism

- Animals can then add a $\Delta 5$ double bond

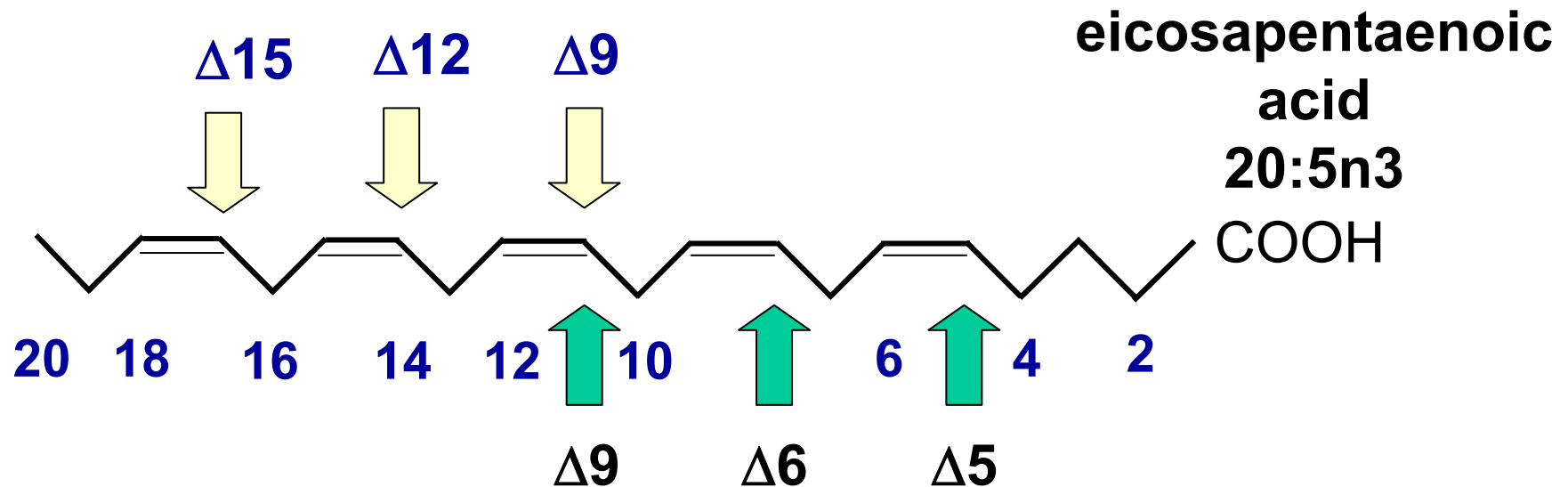

Fatty Acid Metabolism

- To make docosahexaenoic acid (DHA, 22:6n3) animals must further elongate the acyl chain to 22 carbons

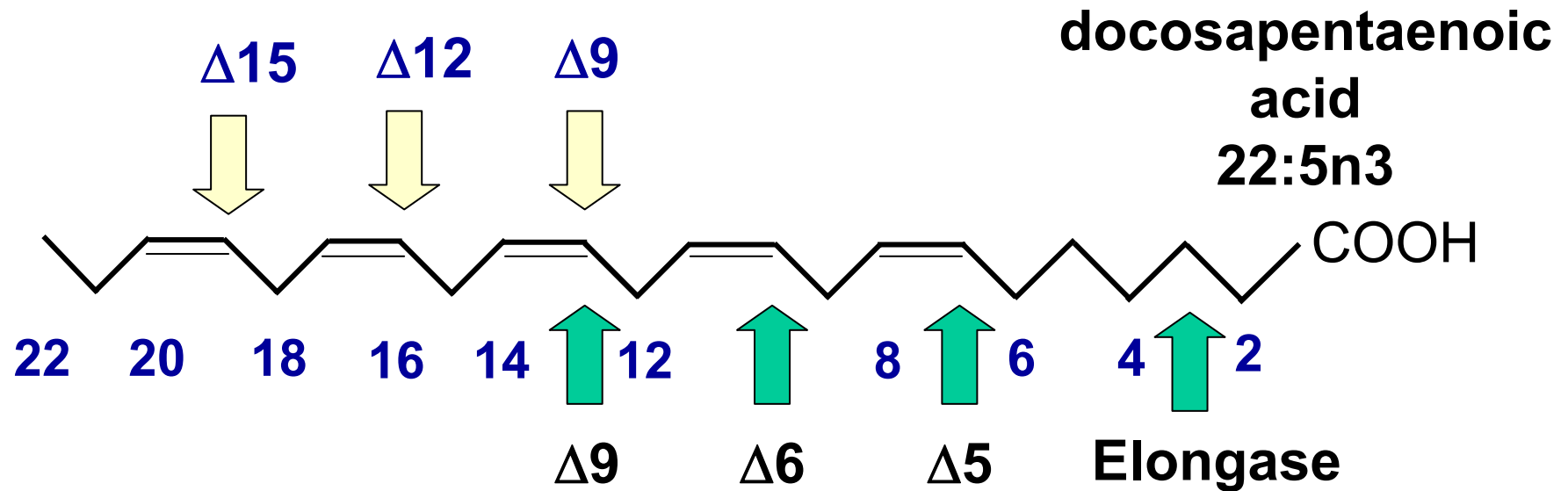

Fatty Acid Metabolism

- Another double bond is inserted at the $\Delta 4$ position

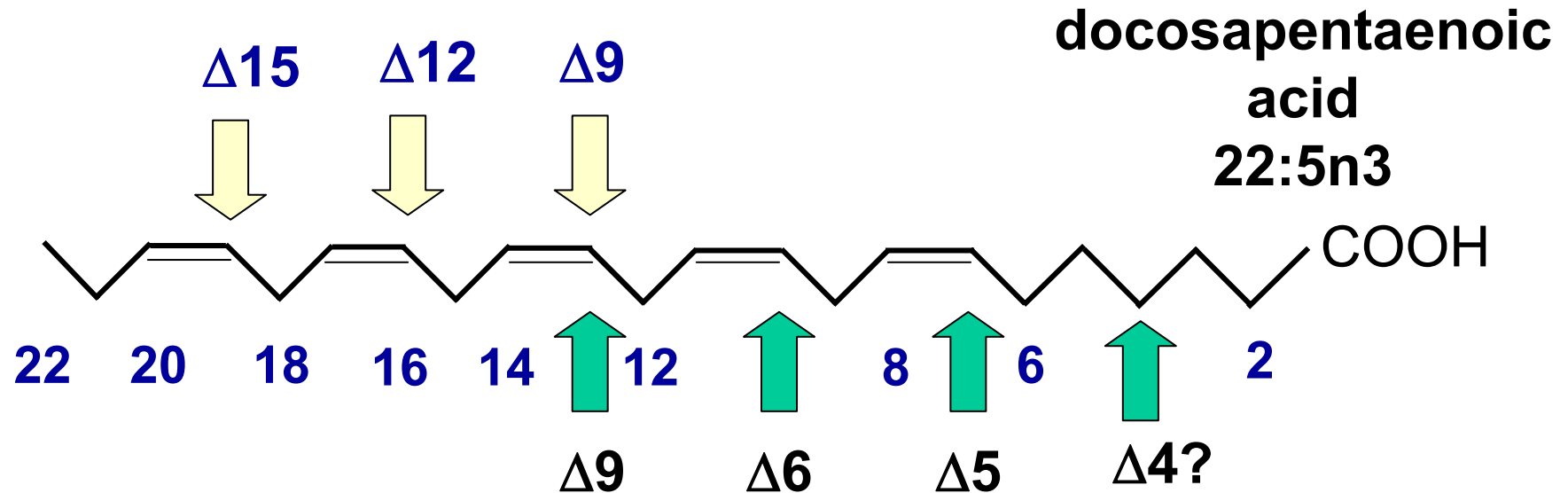

Fatty Acid Metabolism

- BUT THERE IS NO $\Delta 4$ DESATURASE

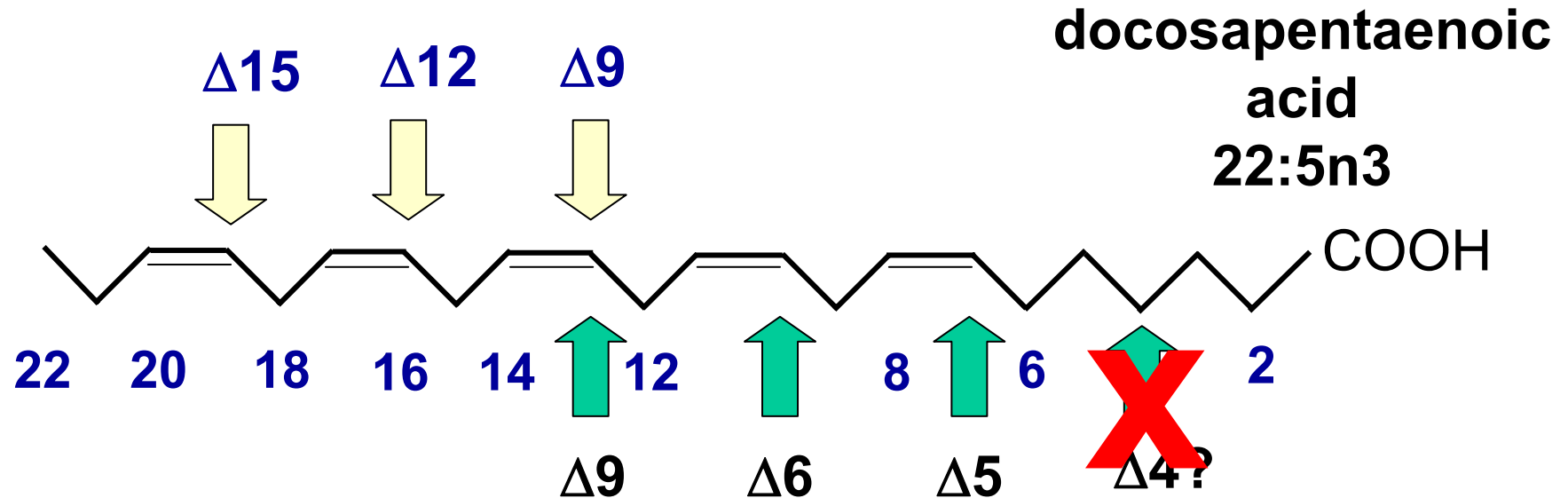

Fatty Acid Metabolism

- To make DHA (22:6n3) the fatty acid must first be elongated again to a 24 carbon chain

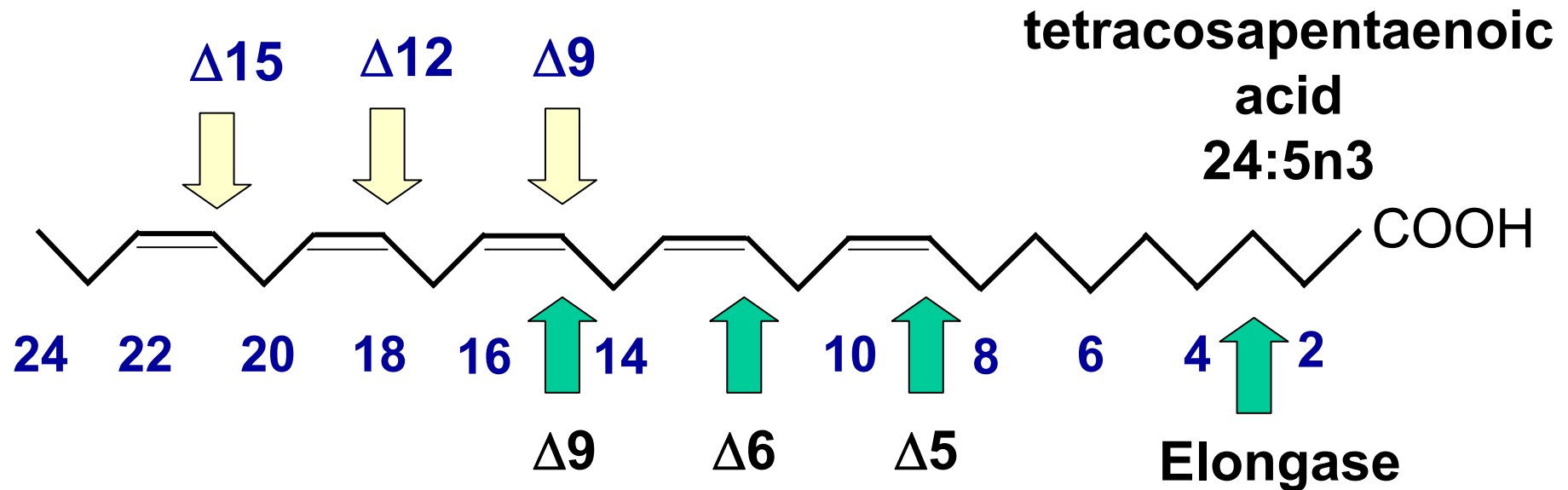

Fatty Acid Metabolism

- Then the chain can be acted upon again by the $\Delta 6$ desaturase yielding 24:6n3

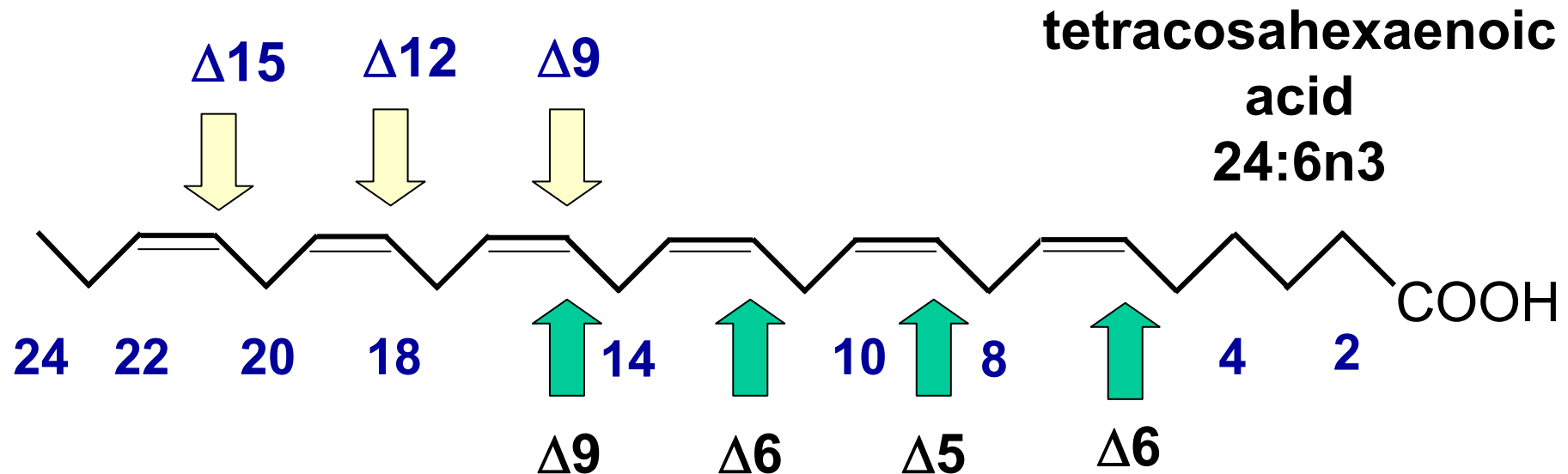

Fatty Acid Metabolism

- The last step in DHA synthesis is a 2-carbon chain shortening by peroxisomal β -oxidation

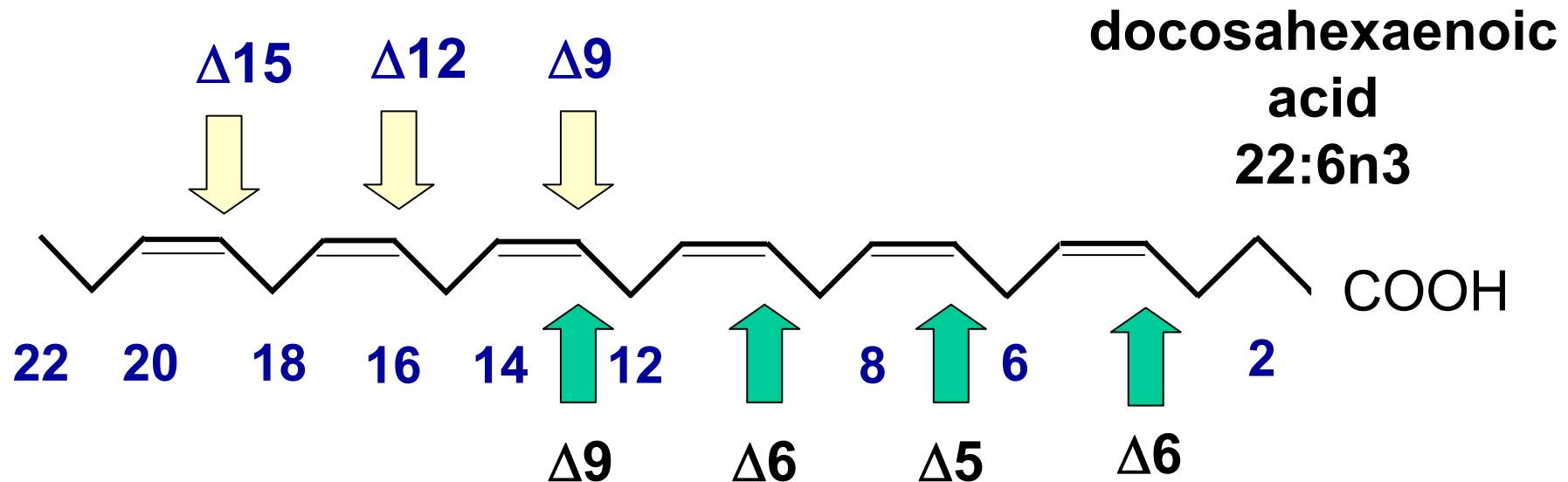

Fatty Acid Metabolism

- Fatty acids with double bonds on the methylene side of an original $\Delta 9$ double bond (n3 and n6 bonds) are of plant origin

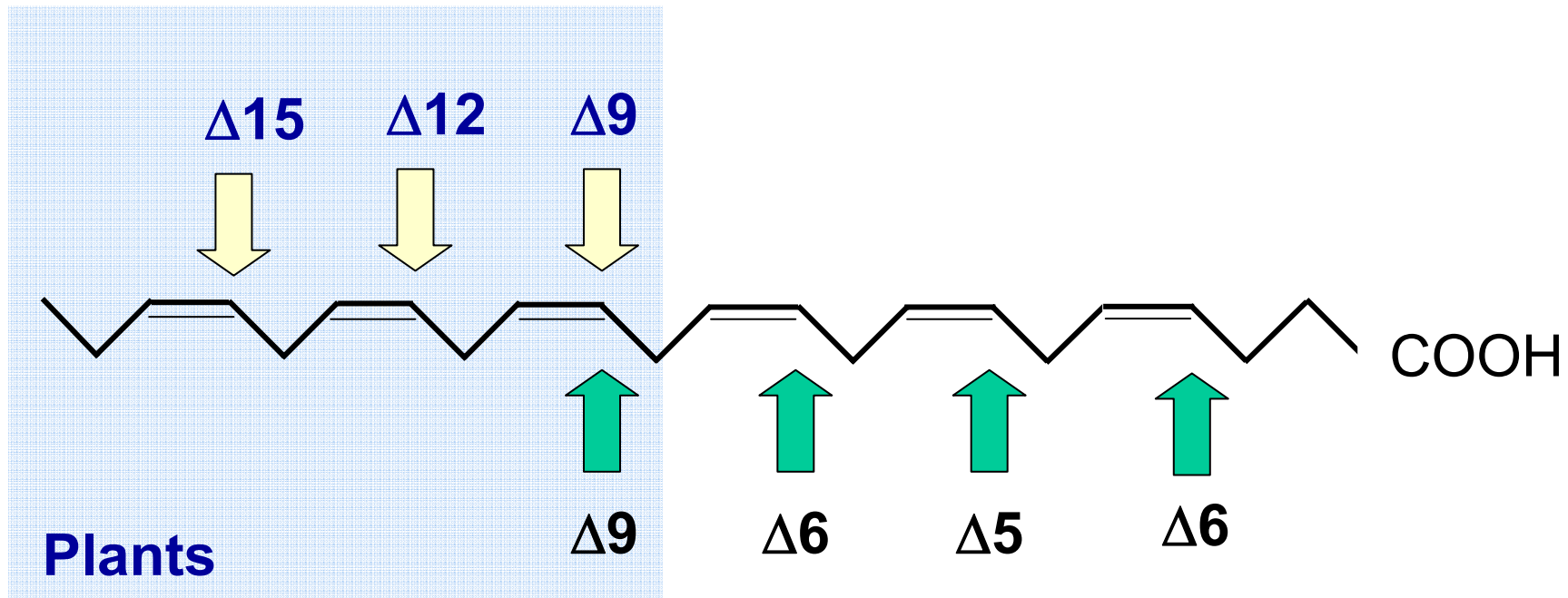

Fatty Acid Metabolism

- Animals then modify these polyunsaturated fatty acids utilizing their own distinct set of desaturases.

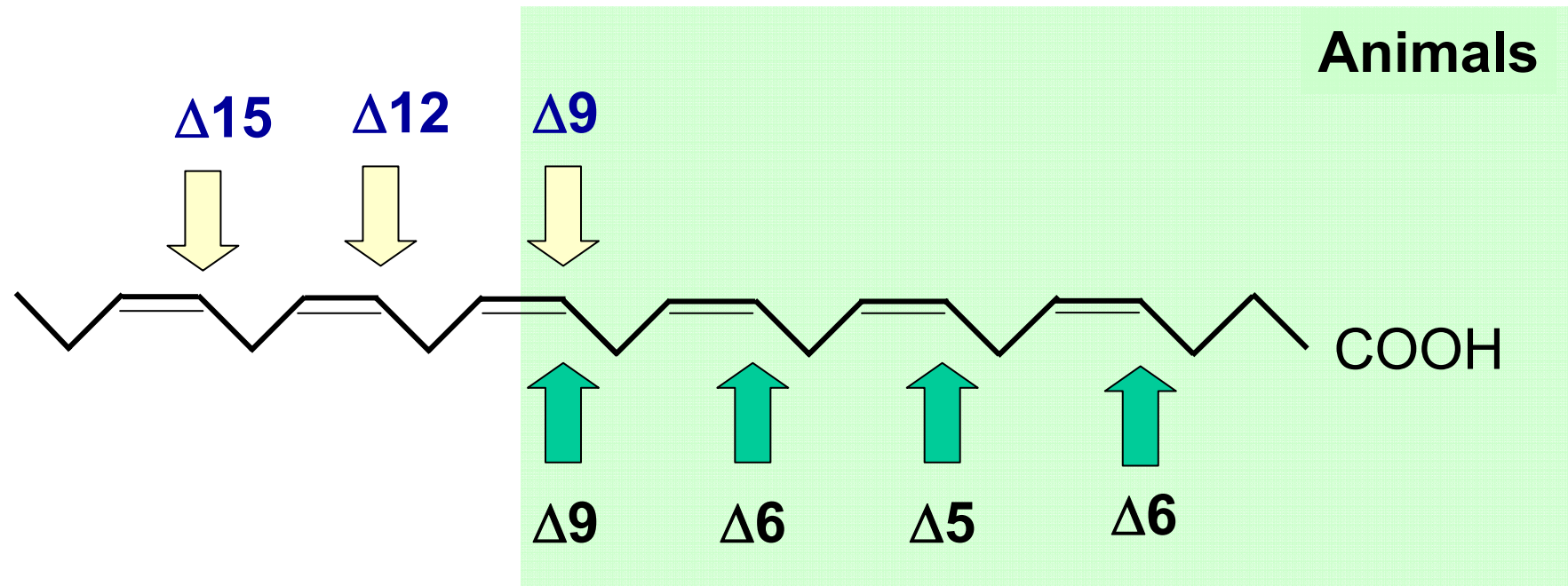

Fatty Acid Metabolism

- **Why two designations?**
 - One is useful to describe biochemical reactions
 - One is useful to track families of fatty acids in nutrition



VS

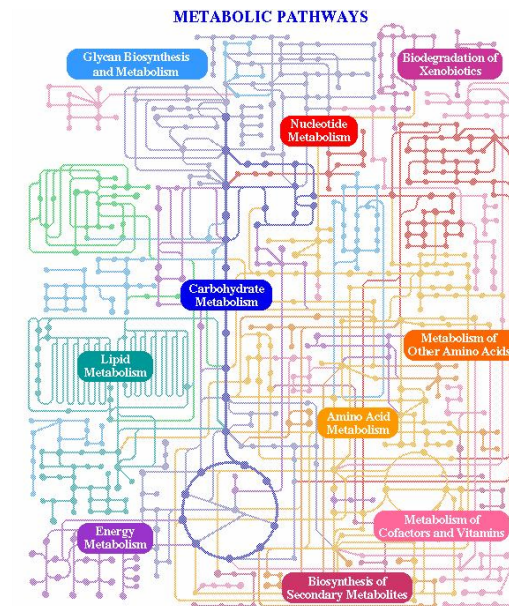

Biochemical Reactions

- Desaturases and elongases act from the carboxy-terminus of the fatty acid
- Therefore, the Δ -designation is useful to describe the biochemistry of fatty acid metabolism

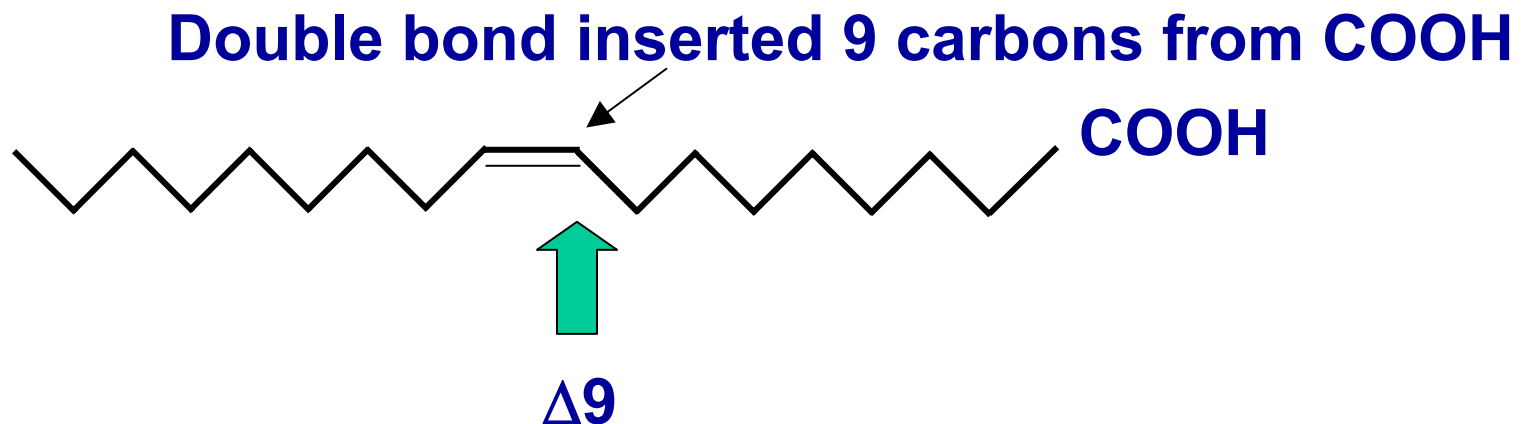

Nutrition

- The n-designation is useful as it allows nutritionists to link diet with tissue fatty acid composition

Linoleic acid (18:2n6)

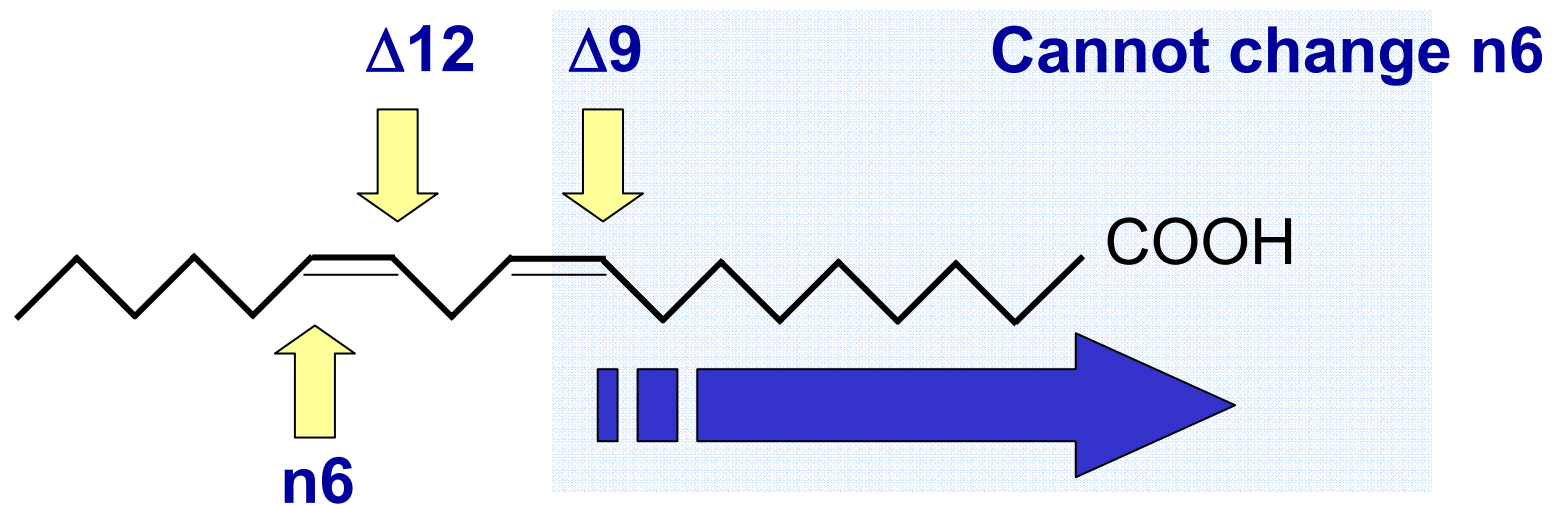

Omega fatty acids (ω)

- Nomenclature based upon position of the first double bond relative to the carbon chain terminal methyl
- Omega-3 fatty acids cannot be synthesized de novo by humans, obtained from fish

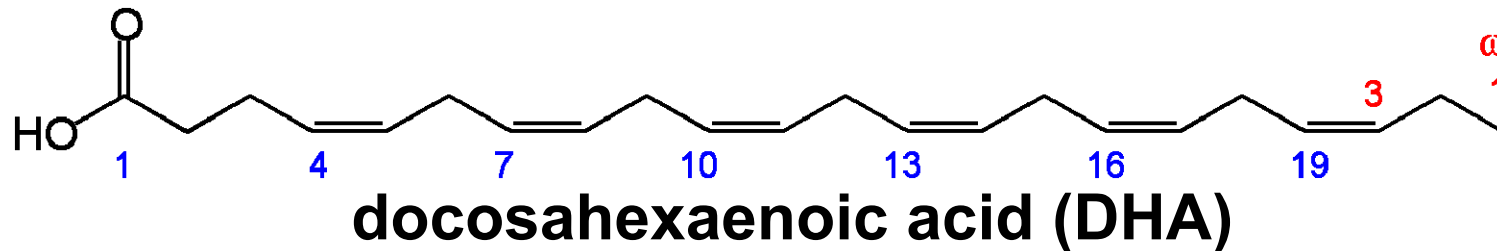

- Omega-6 fatty acids are obtained from diet (grains, etc) and can be synthesized

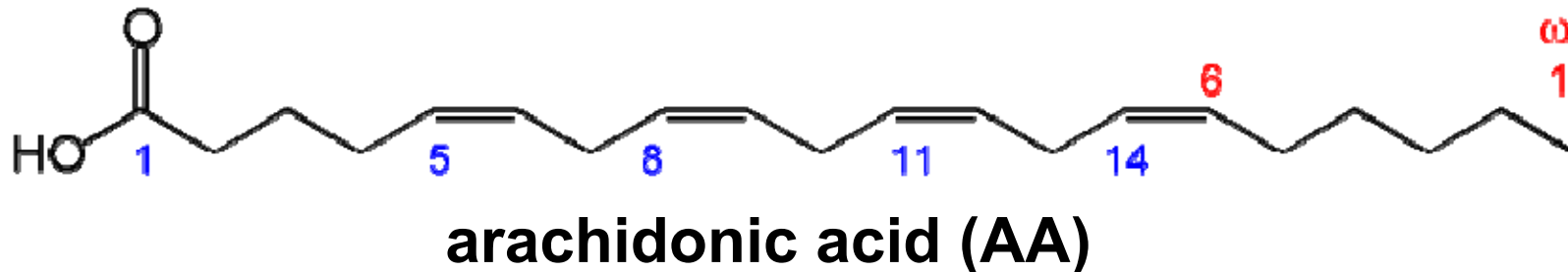

Fatty acid modification

- Activated FFA (acyl-CoA)
- Elongation
- β -oxidation
- Desaturation
 - up to C9 in animals
 - >C9 occurs only in plants

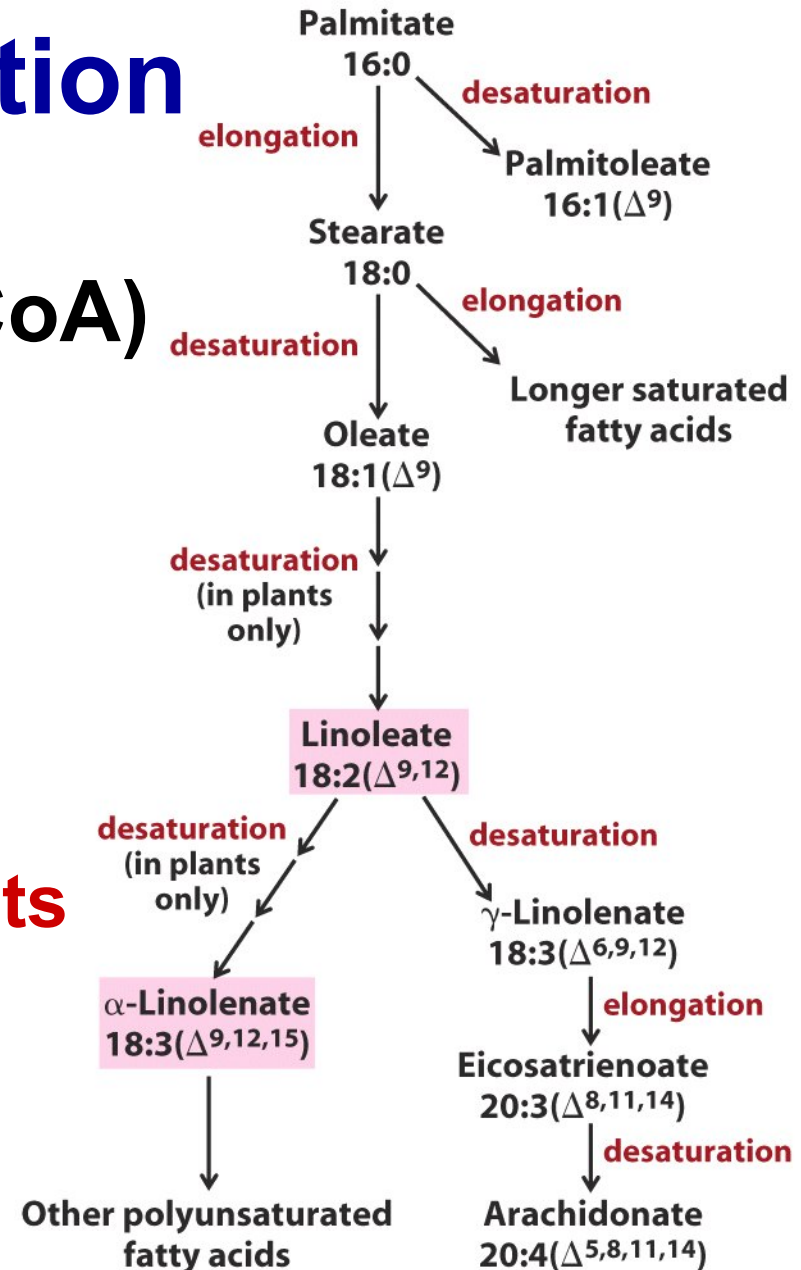

Essential FA Metabolism

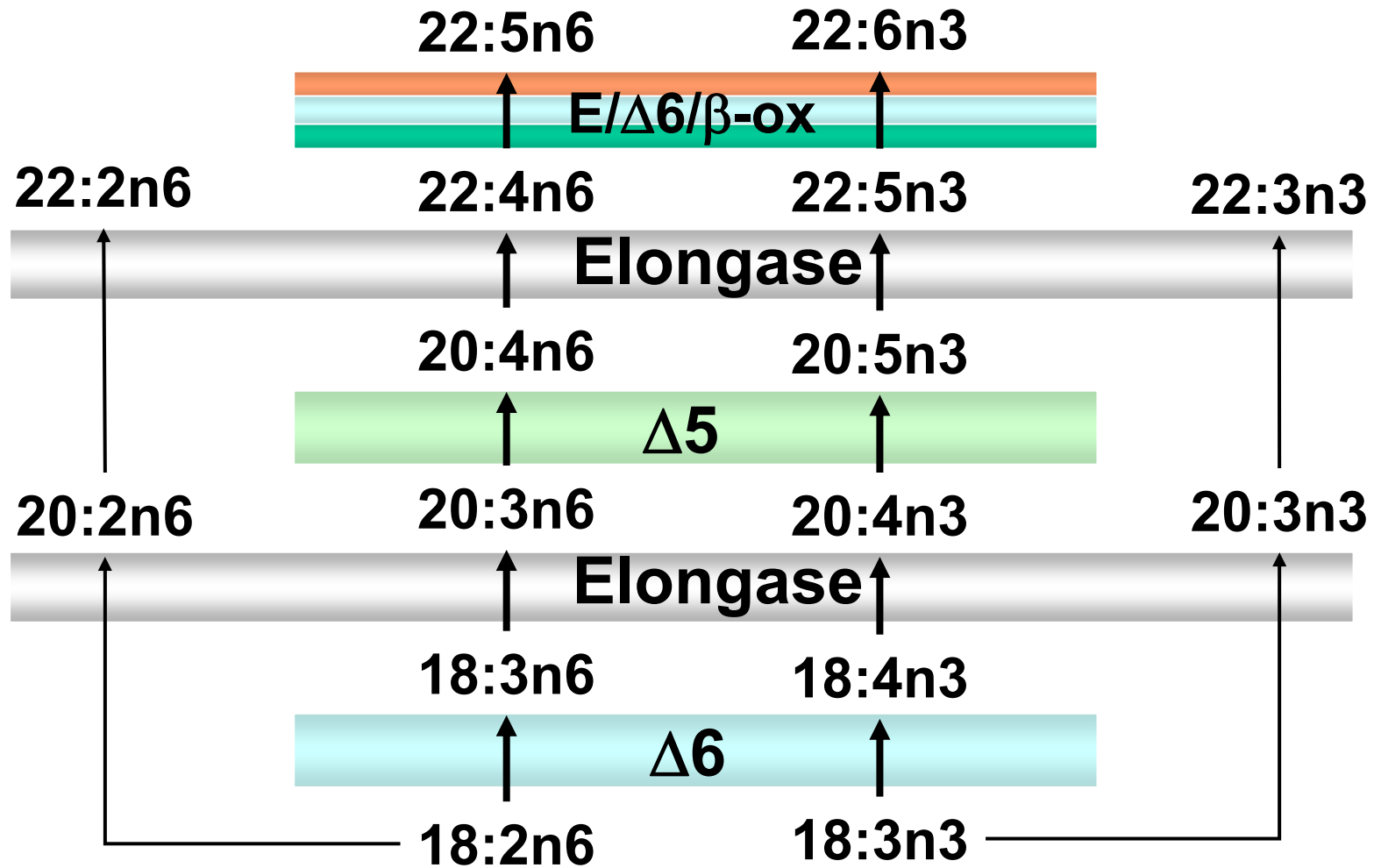

De Novo Metabolism

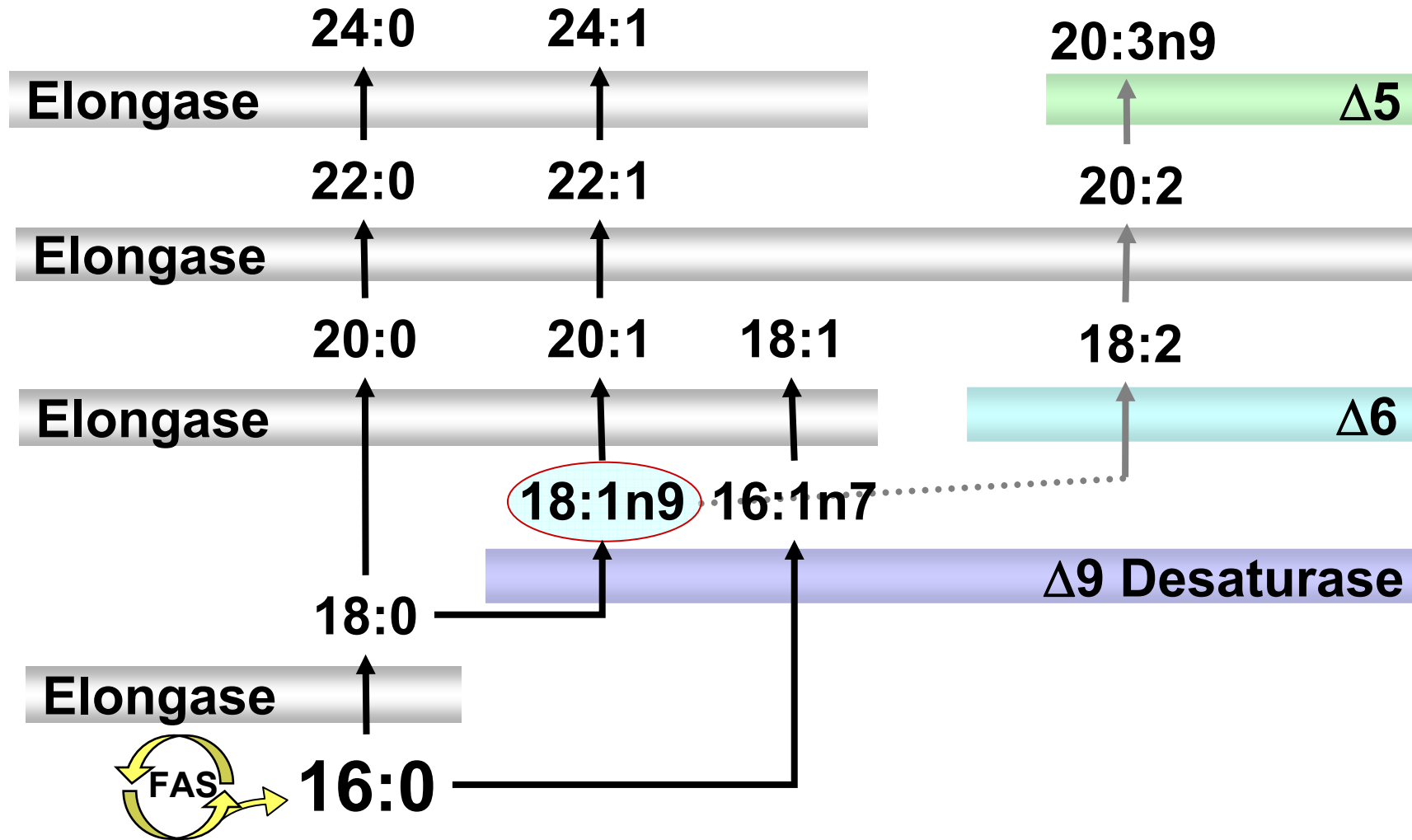

Trans-fat contains “trans” vs. “cis” bond

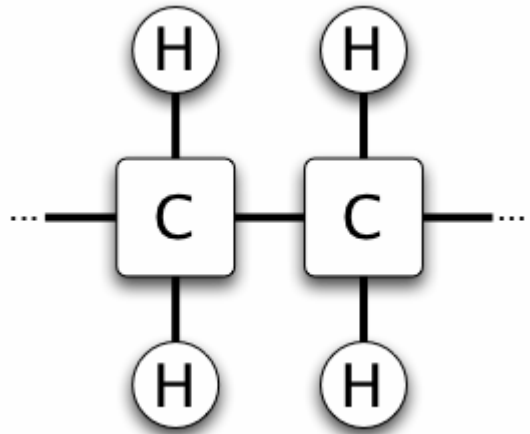

saturated

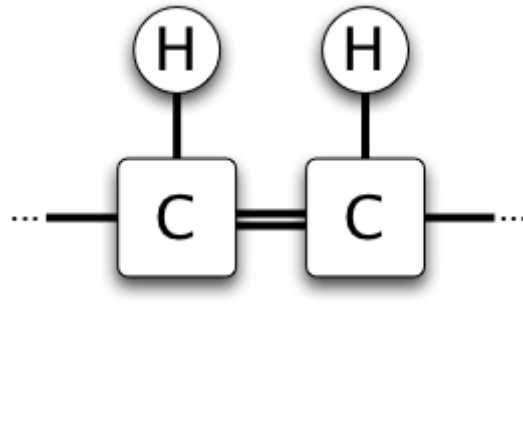

cis double bond

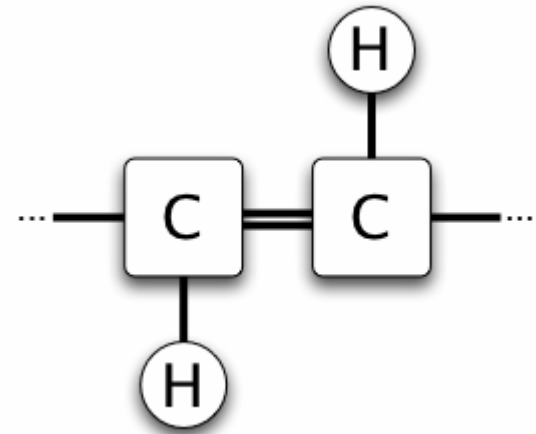

trans double bond

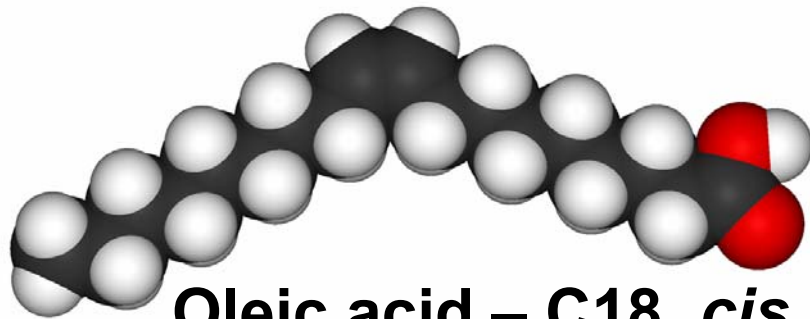

Oleic acid – C18, *cis*
Melting point = 13°C

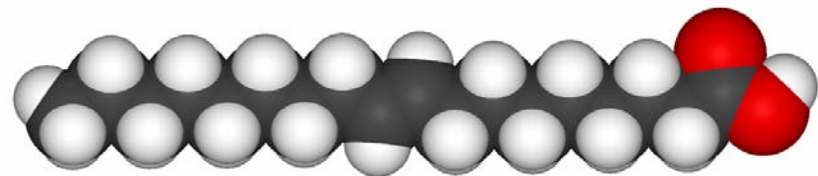

Elaidic acid – C18, *trans*
Melting point = 45°C

TABLE 12.1 Some naturally occurring fatty acids in animals

Number of carbons	Number of double bonds	Common name	Systematic name	Formula
12	0	Laurate	<i>n</i> -Dodecanoate	$\text{CH}_3(\text{CH}_2)_{10}\text{COO}^-$
14	0	Myristate	<i>n</i> -Tetradecanoate	$\text{CH}_3(\text{CH}_2)_{12}\text{COO}^-$
16	0	Palmitate	<i>n</i> -Hexadecanoate	$\text{CH}_3(\text{CH}_2)_{14}\text{COO}^-$
18	0	Stearate	<i>n</i> -Octadecanoate	$\text{CH}_3(\text{CH}_2)_{16}\text{COO}^-$
20	0	Arachidate	<i>n</i> -Eicosanoate	$\text{CH}_3(\text{CH}_2)_{18}\text{COO}^-$
22	0	Behenate	<i>n</i> -Docosanoate	$\text{CH}_3(\text{CH}_2)_{20}\text{COO}^-$
24	0	Lignocerate	<i>n</i> -Tetracosanoate	$\text{CH}_3(\text{CH}_2)_{22}\text{COO}^-$
16	1	Palmitoleate	<i>cis</i> - Δ^9 -Hexadecenoate	$\text{CH}_3(\text{CH}_2)_5\text{CH}=\text{CH}(\text{CH}_2)_7\text{COO}^-$
18	1	Oleate	<i>cis</i> - Δ^9 -Octadecenoate	$\text{CH}_3(\text{CH}_2)_7\text{CH}=\text{CH}(\text{CH}_2)_7\text{COO}^-$
18	2	Linoleate	<i>cis,cis</i> - Δ^9, Δ^{12} - Octadecadienoate	$\text{CH}_3(\text{CH}_2)_4(\text{CH}=\text{CHCH}_2)_2(\text{CH}_2)_6\text{COO}^-$
18	3	Linolenate	<i>all-cis</i> - $\Delta^9, \Delta^{12}, \Delta^{15}$ - Octadecatrienoate	$\text{CH}_3\text{CH}_2(\text{CH}=\text{CHCH}_2)_3(\text{CH}_2)_6\text{COO}^-$
20	4	Arachidonate	<i>all-cis</i> $\Delta^5, \Delta^8, \Delta^{11}, -\Delta^{14}$ Eicosatetraenoate	$\text{CH}_3(\text{CH}_2)_4(\text{CH}=\text{CHCH}_2)_4(\text{CH}_2)_2\text{COO}^-$

Ex) Linoleate, linoleic acid **18:2n6**

cis,cis- Δ^9, Δ^{12} –octadecatrienoate

an ω -6 fatty acid

Fatty acid biosynthesis

- **Where?** In the cytoplasm in: liver, adipose and mammary glands
- **How?** Stepwise incorporation of 2 carbon atoms from Acetyl-CoA
- **Cost?** both ATP and NADPH

Overall equation for synthesis of 16:0 (palmitate, hexadecanoate)

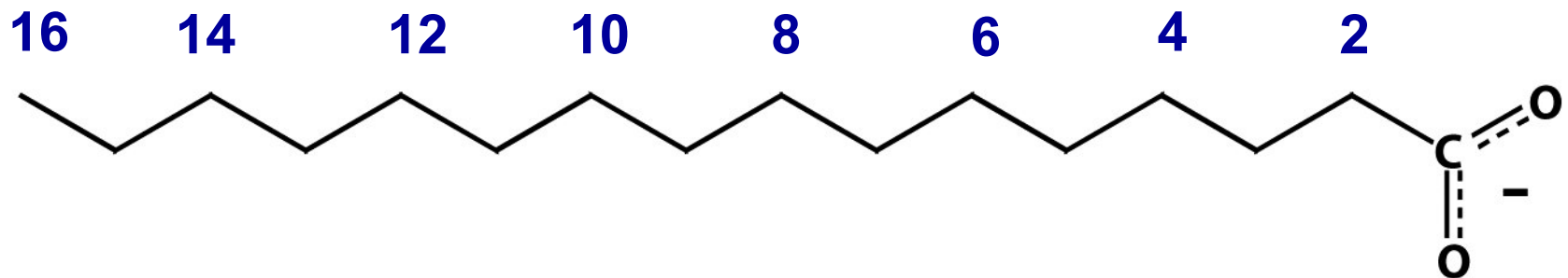
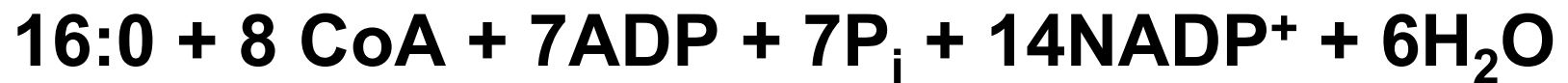

Palmitate

Fatty acid synthase system

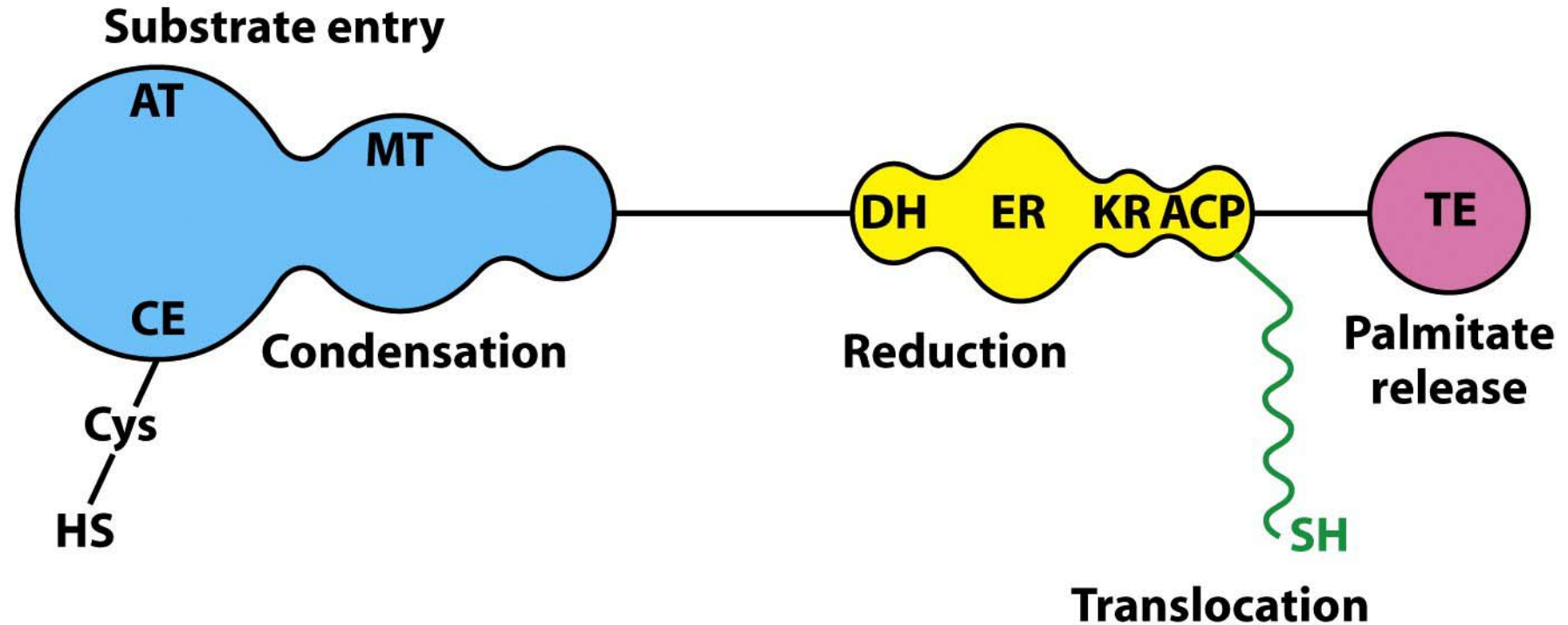

Domain 1:

AT acetyl transferase
MT malonyl transferase
CE condensing enzyme
(= β -ketoacyl synthase, KS)

Domain 2:

DH dehydratase
ER enoyl reductase
KR β -ketoacyl reductase
ACP acyl carrier protein

Domain 3:

TE thioesterase

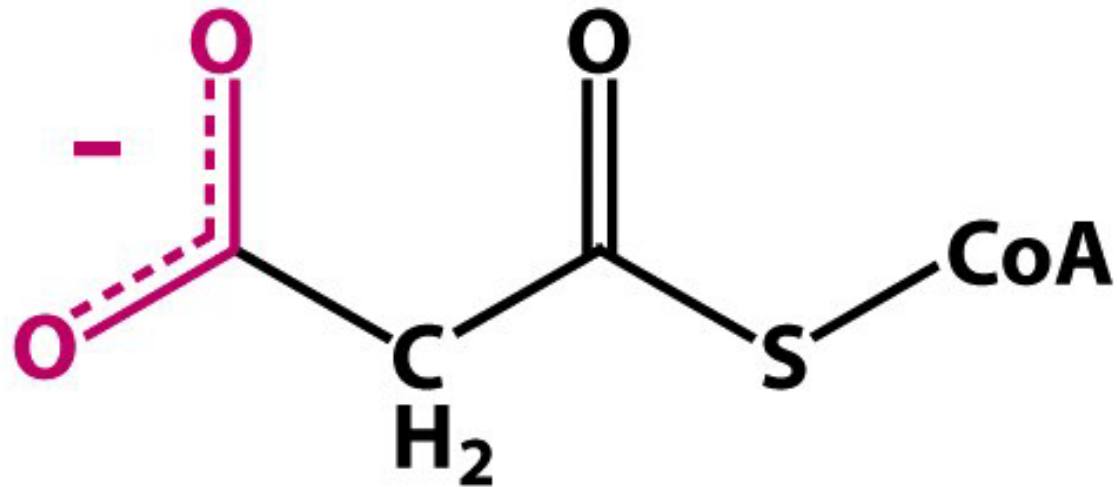

Malonyl CoA

”activated 2-carbon donor”
committed step in FA synthesis

Coenzyme A (CoA-SH)

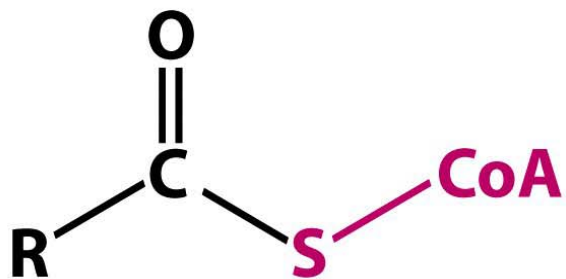
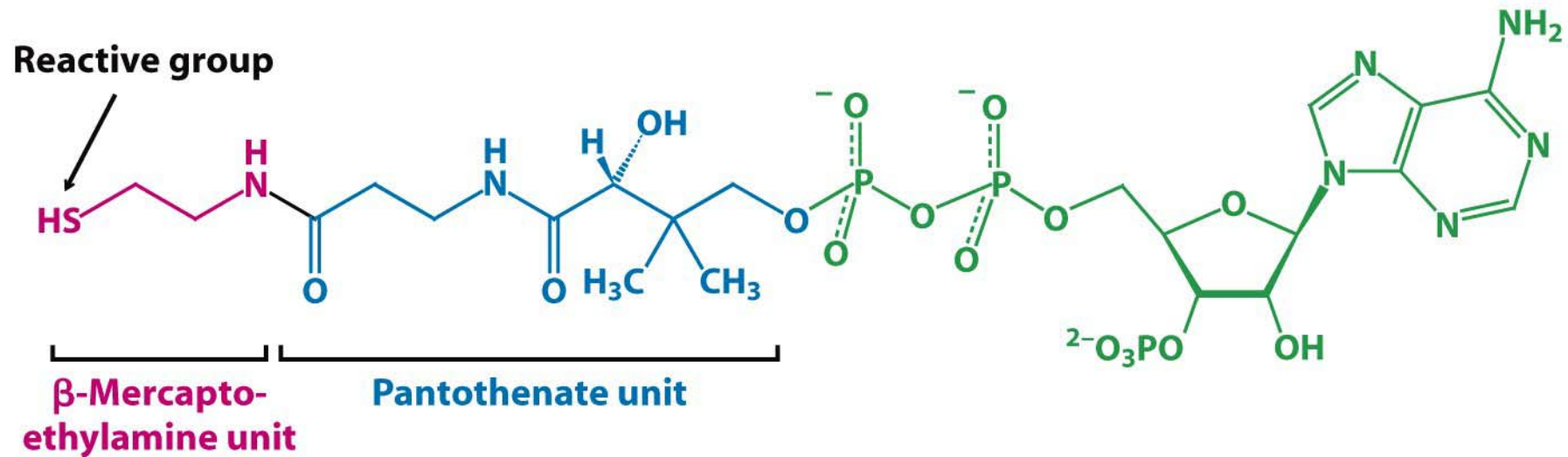

Acyl CoA

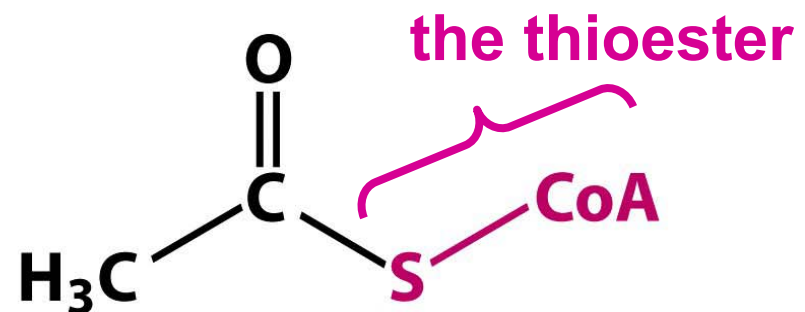

Acetyl CoA

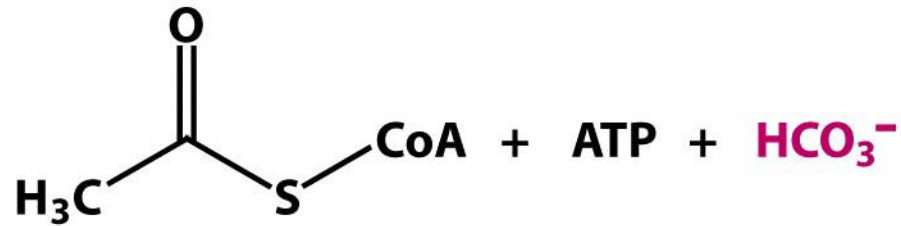

Acetyl-CoA

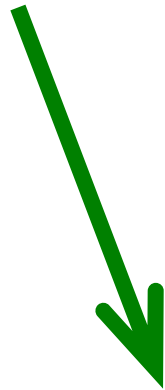

Acetyl-CoA-carboxylase (ACC)
the committed step in FA
synthesis

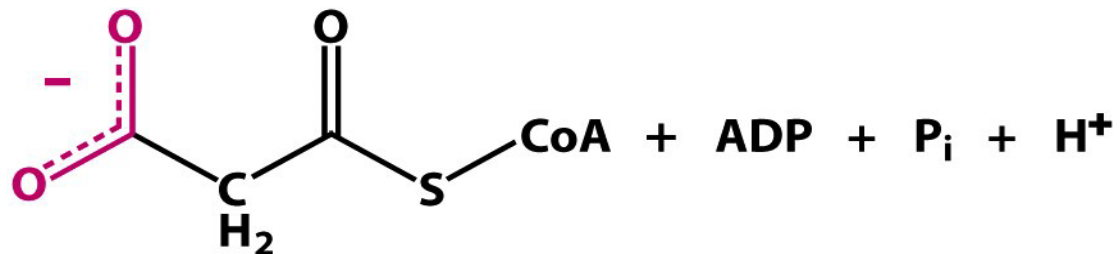

Malonyl-CoA

Elongation phase of FA synthesis

Acetyl transacylase

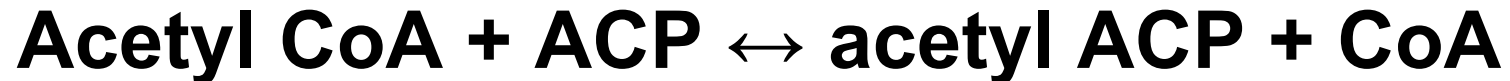

Malonyl transacylase



ACP – acyl carrier protein

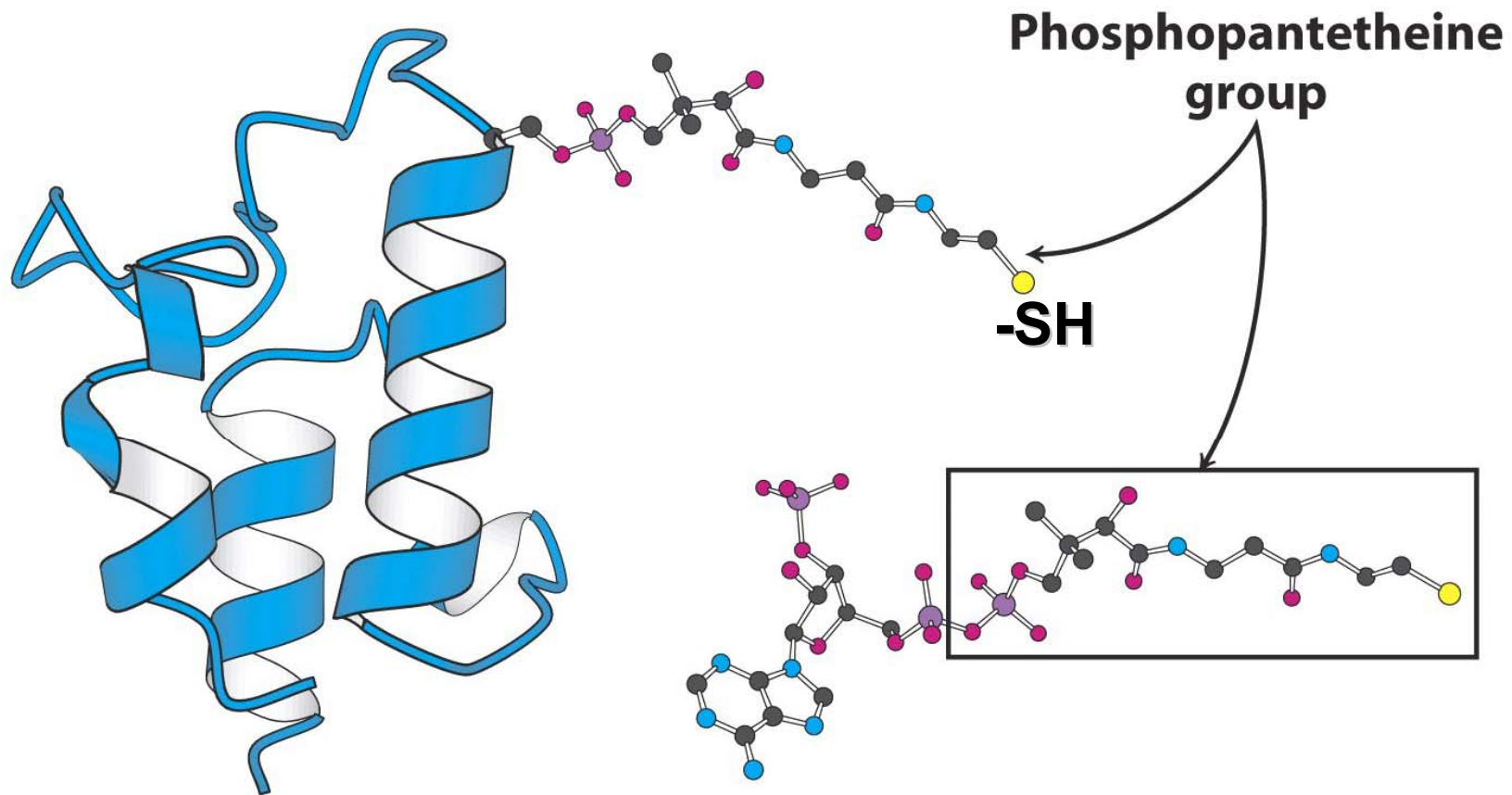

Acyl carrier protein

Coenzyme A



single polypeptide chain of 77 residues

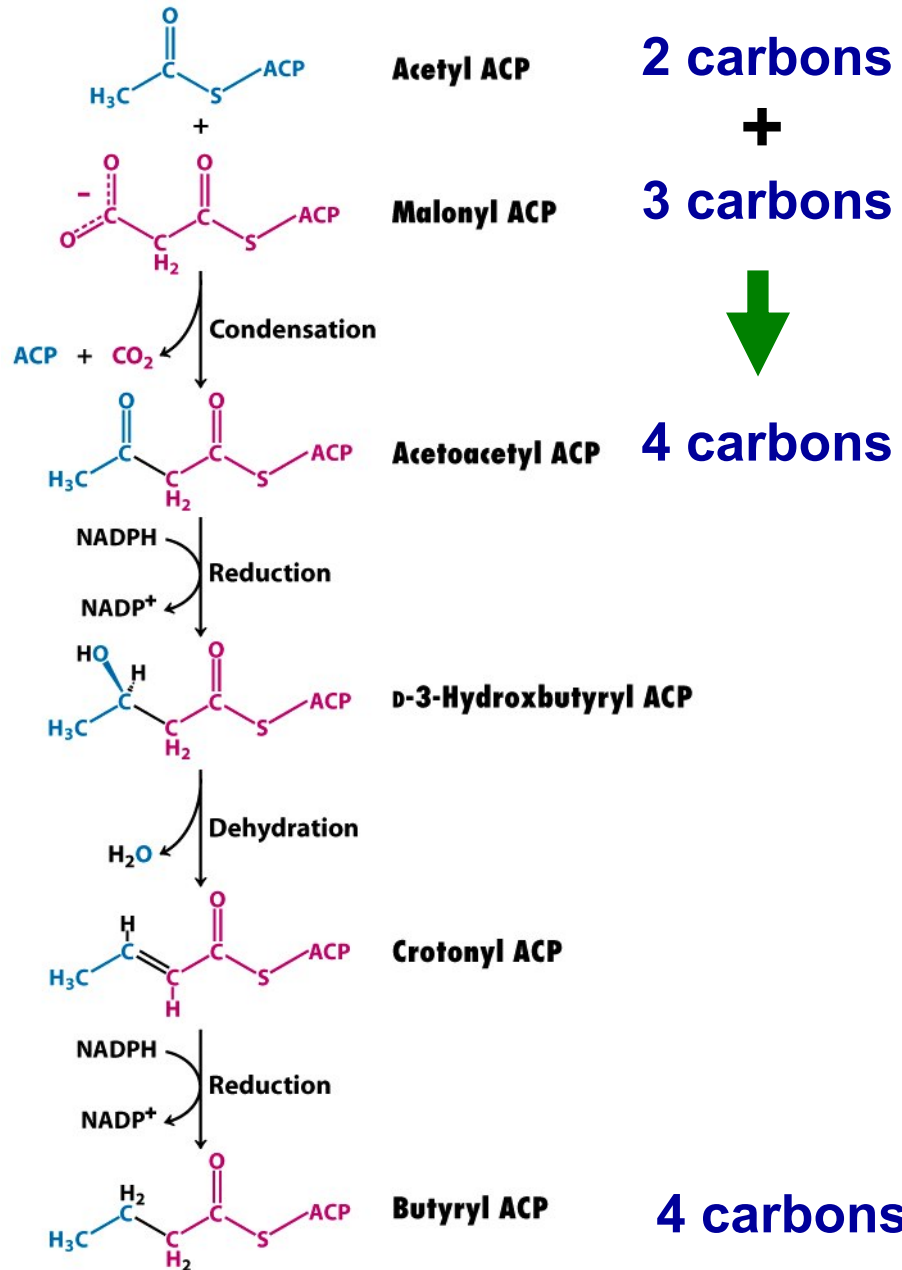

Fatty acid synthase reaction sequence

7 rounds gives:
16:0, palmitate

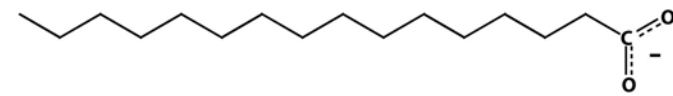

Palmitate

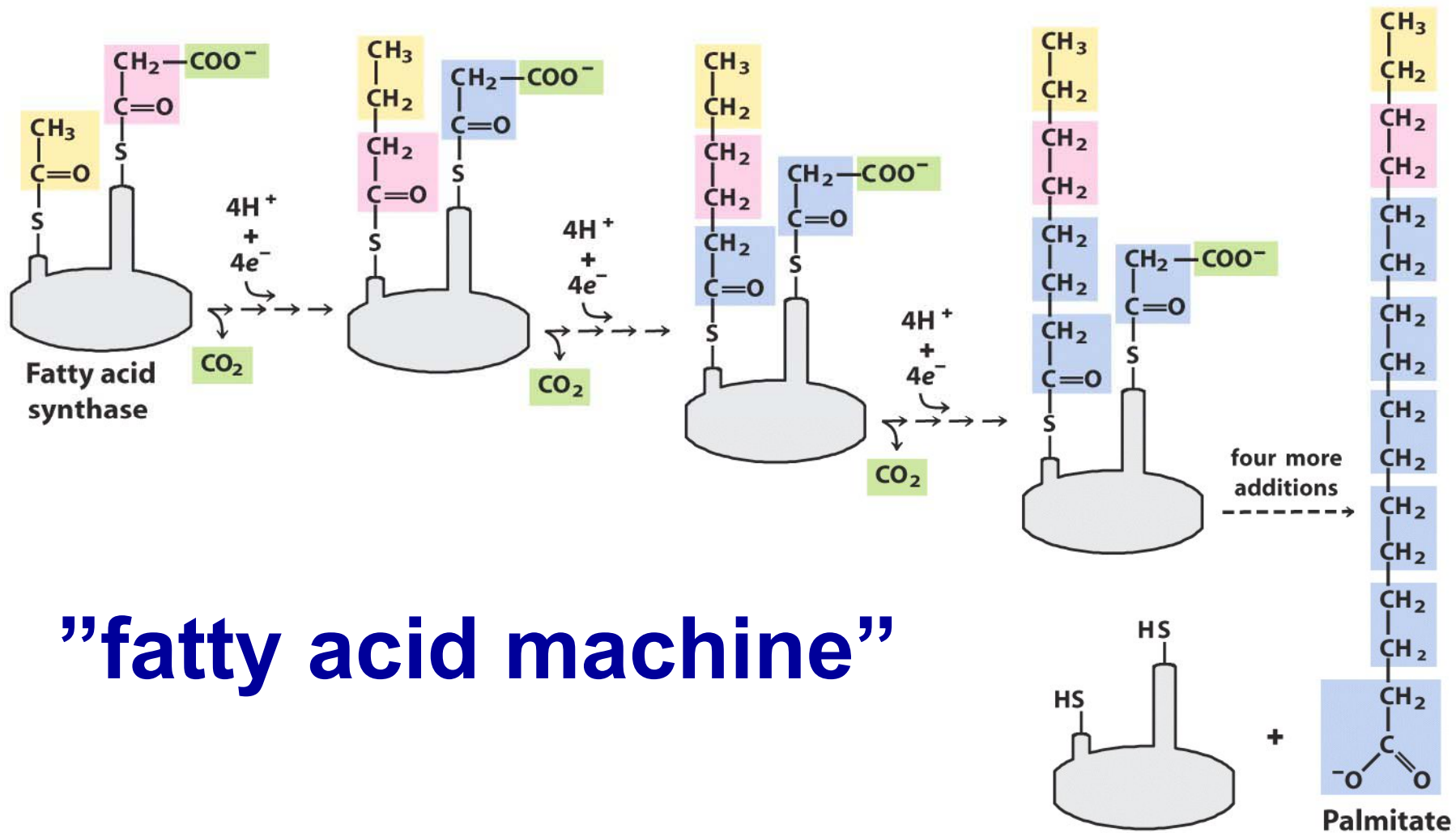

”fatty acid machine”

AT = acetyl transferase
MT = malonyl transferase
KS = β -ketoacyl synthase,
(CE condensing enzyme)
HD = dehydratase
ER = enoyl reductase
KR = β -ketoacyl reductase
ACP = acyl carrier protein

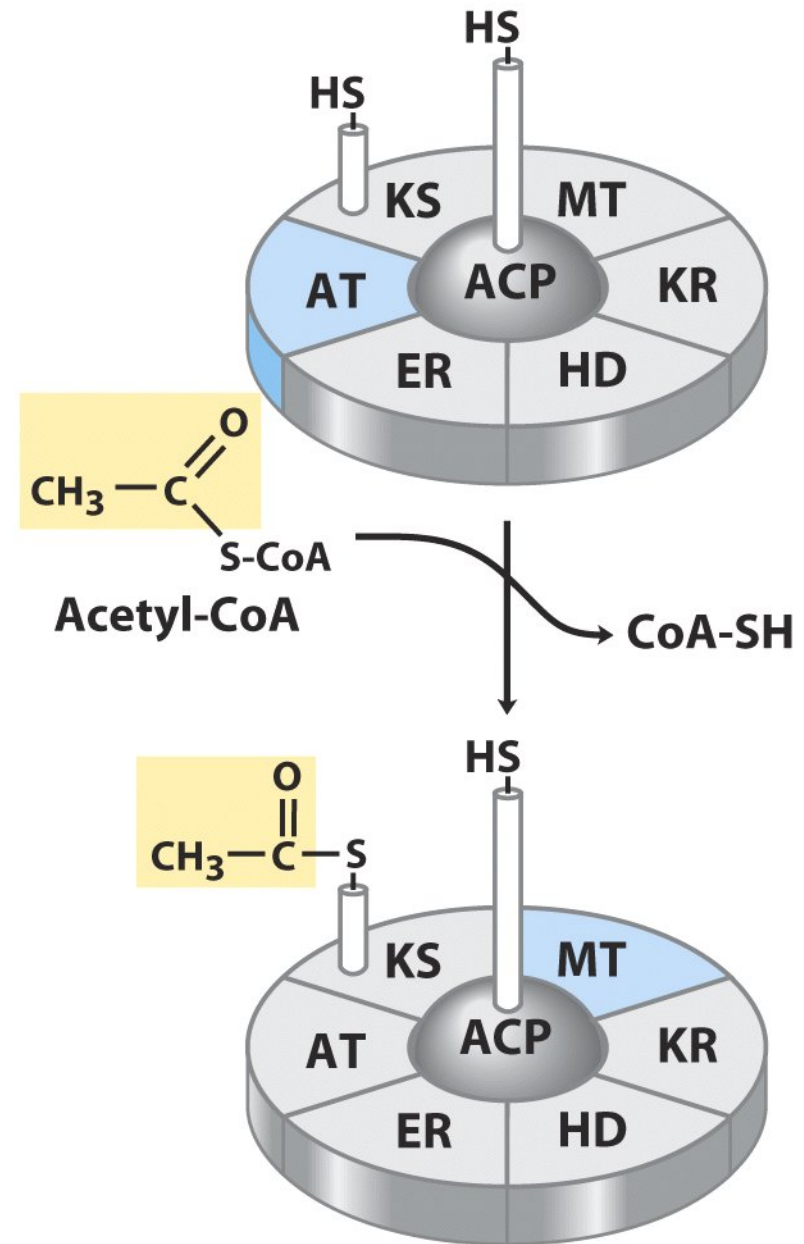

AT = acetyl transferase
MT = malonyl transferase
KS = β -ketoacyl synthase,
(CE condensing enzyme)
HD = dehydratase
ER = enoyl reductase
KR = β -ketoacyl reductase
ACP = acyl carrier protein

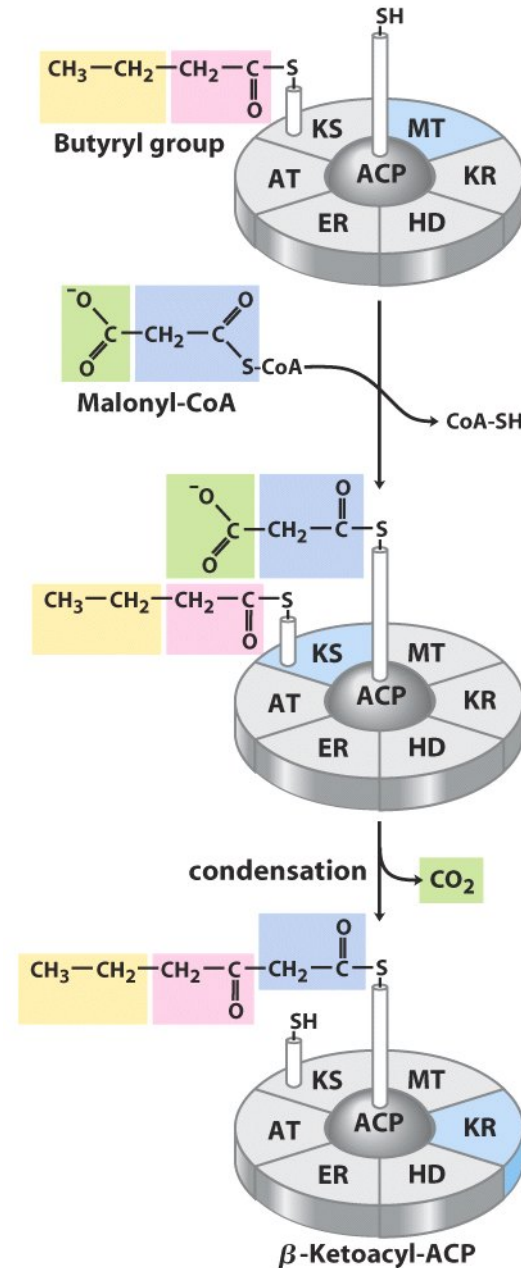

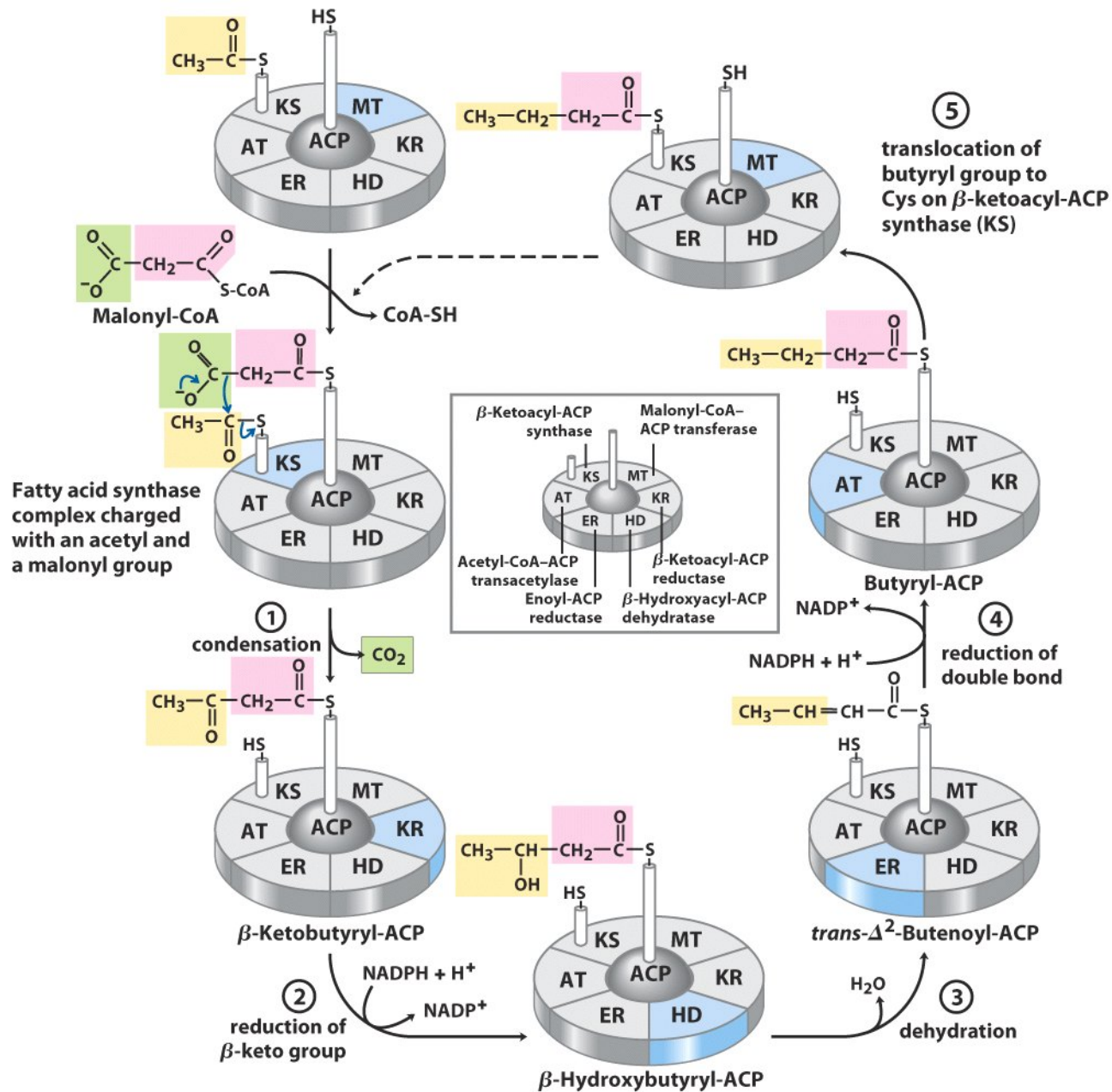

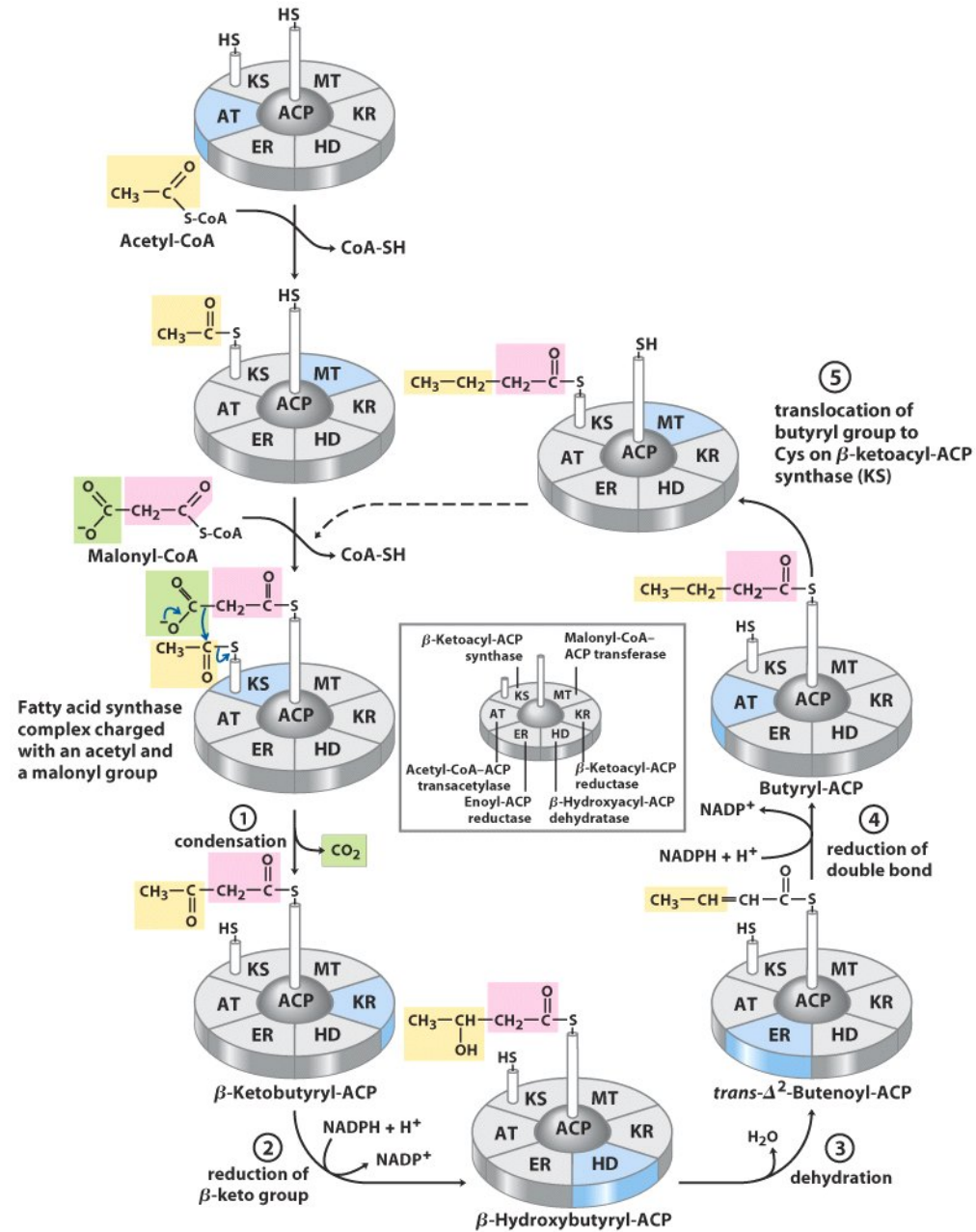

Ex) The complete reaction for synthesis of 16:0

= 1 Ac-CoA + 7 Mal-CoA

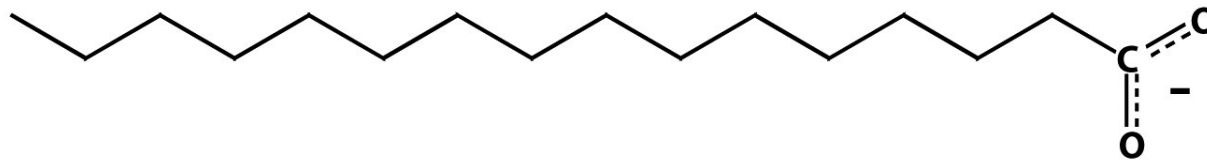
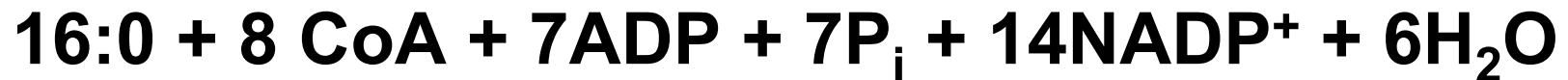

Palmitate
(ionized form of palmitic acid)

Transfer of Acetyl-CoA to the cytosol

→ FA synthesized in cytoplasm, acetyl CoA formed from pyruvate in mitochondria

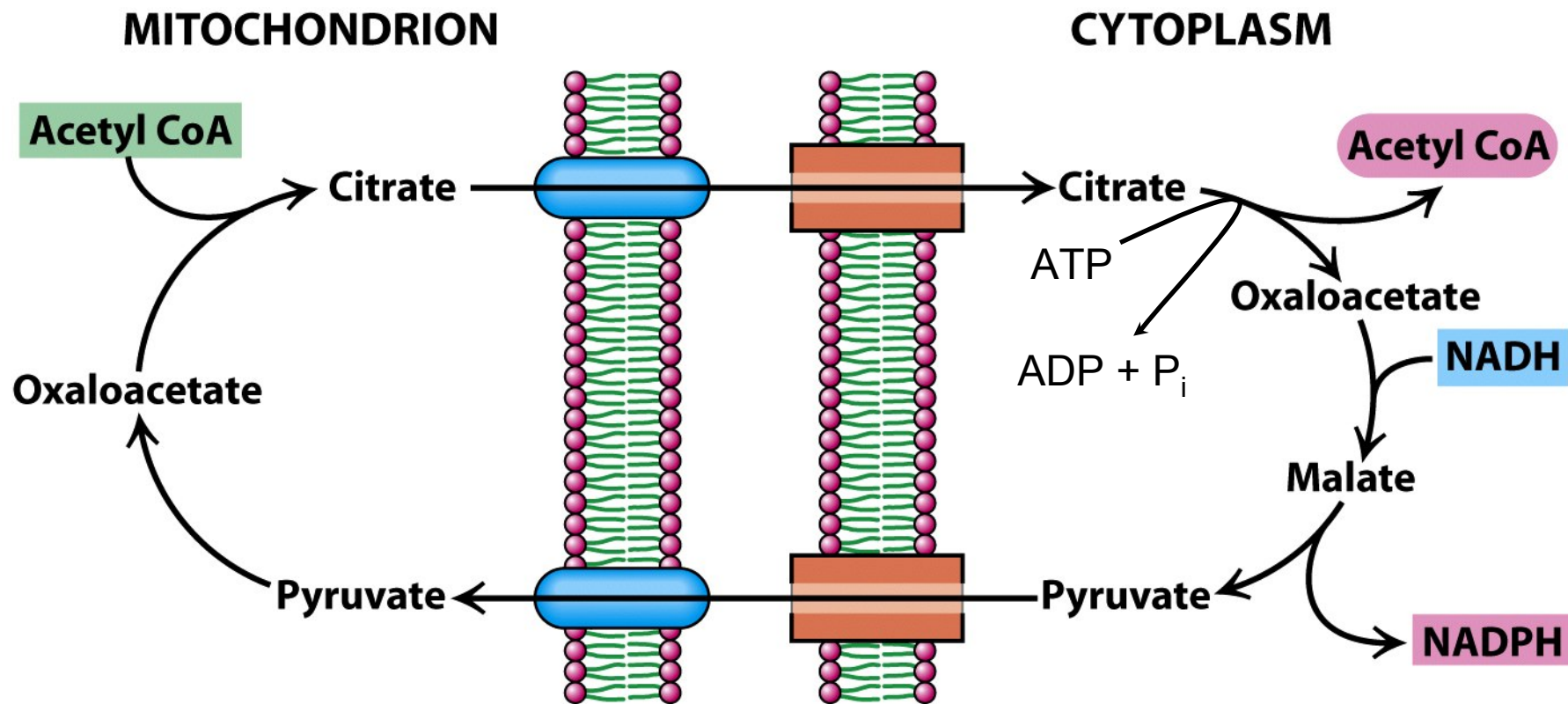

2 Ways to Generate NADPH

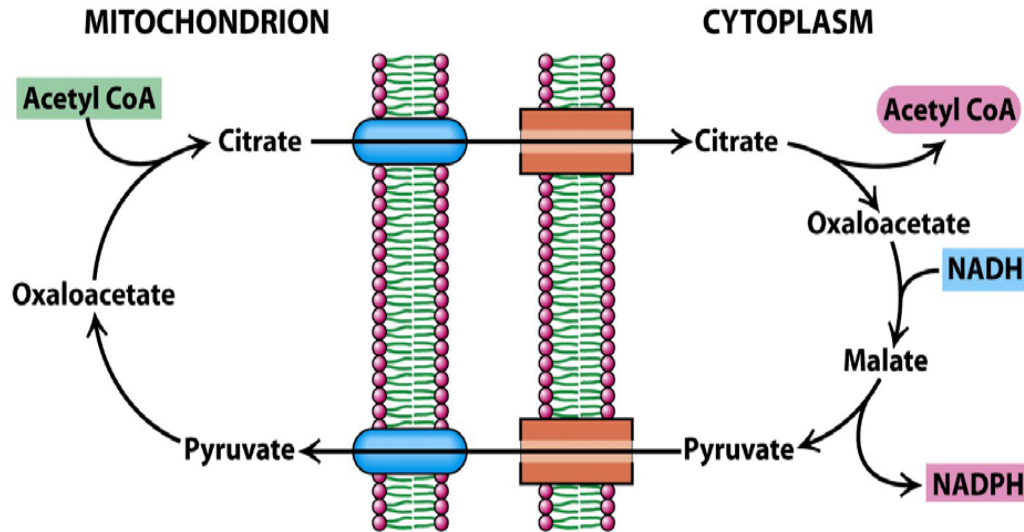

1. Malic enzyme
(NADP⁺-linked malate enzyme)

2. HMP-shunt
(hexose monophosphate)

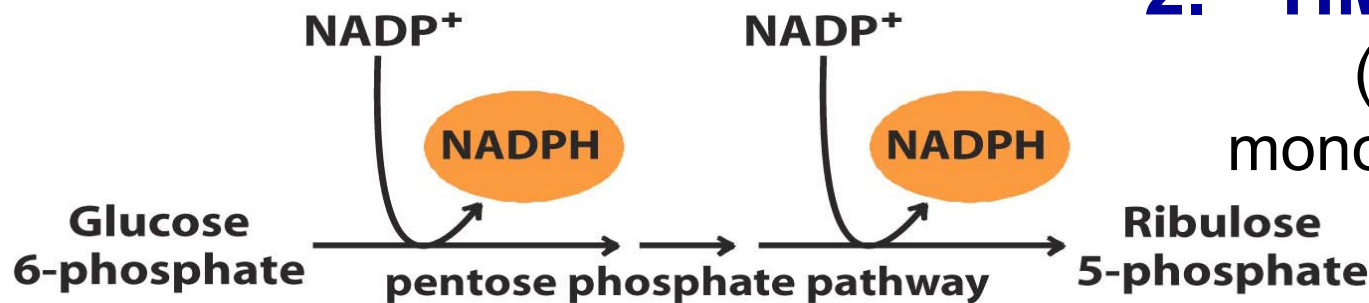

occurs exclusively in the cytoplasm = accounts for 60% of NADPH

Fatty acid synthesis requires the integration of multiple metabolic pathways

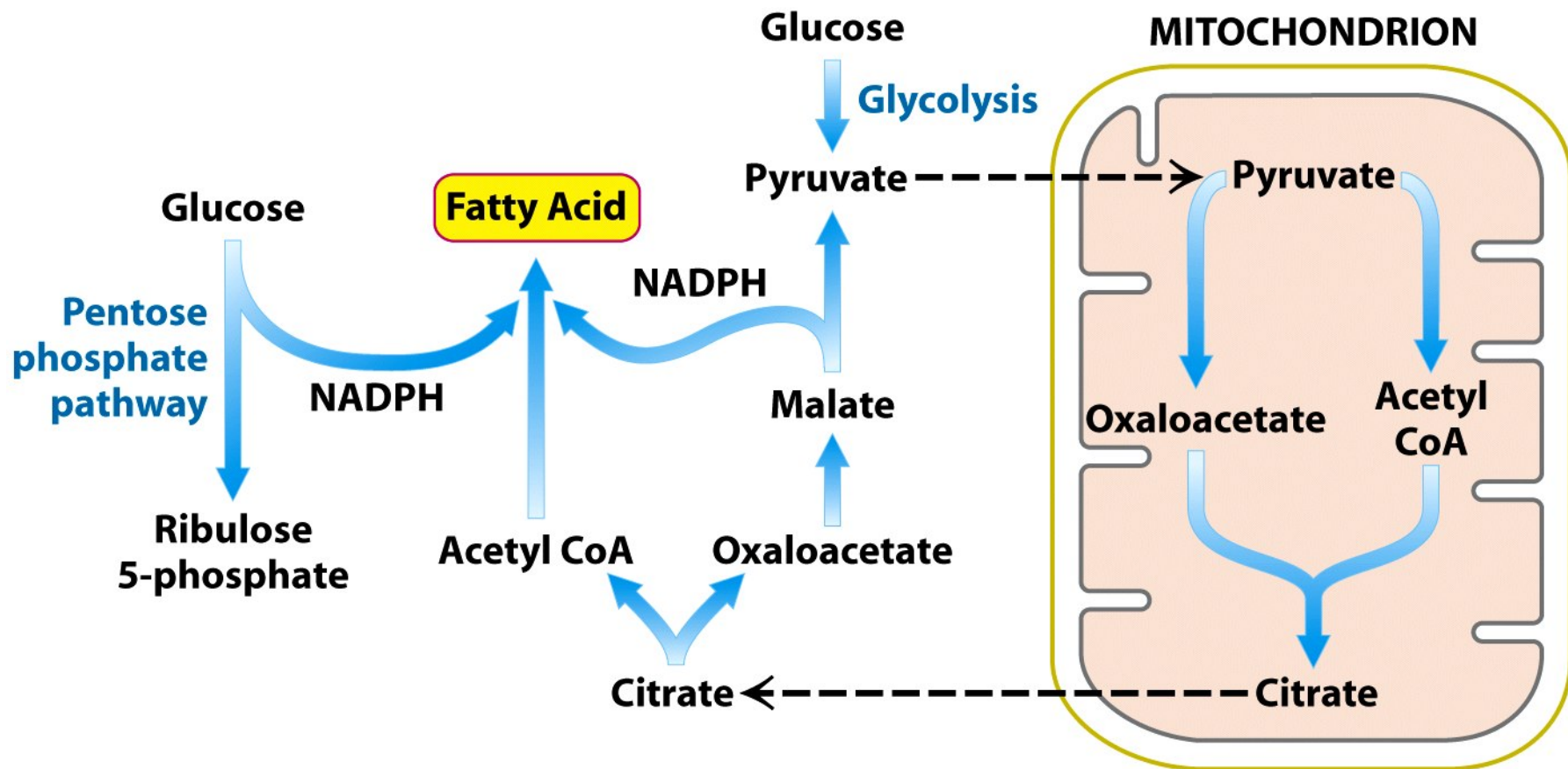

EICOSANOIDS

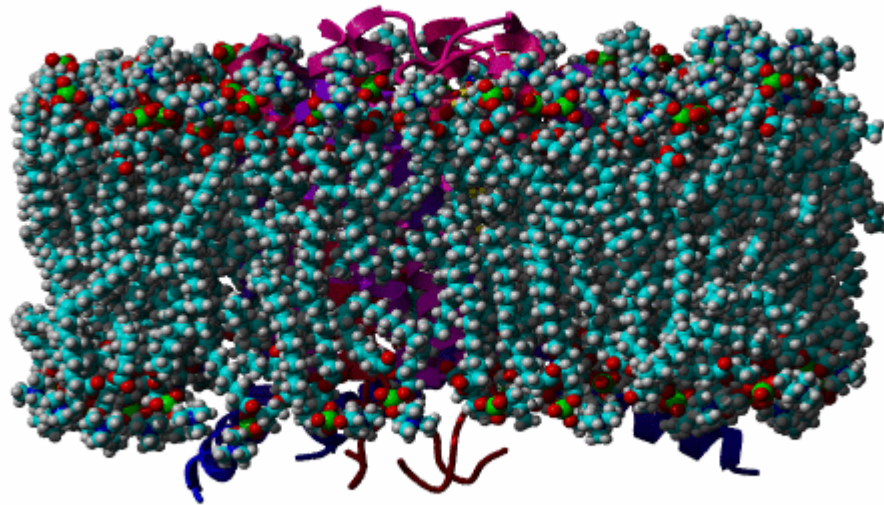

AA is metabolized to inflammatory mediators

Many current anti-inflammatory & pain medicines inhibit some portion of the AA pathway

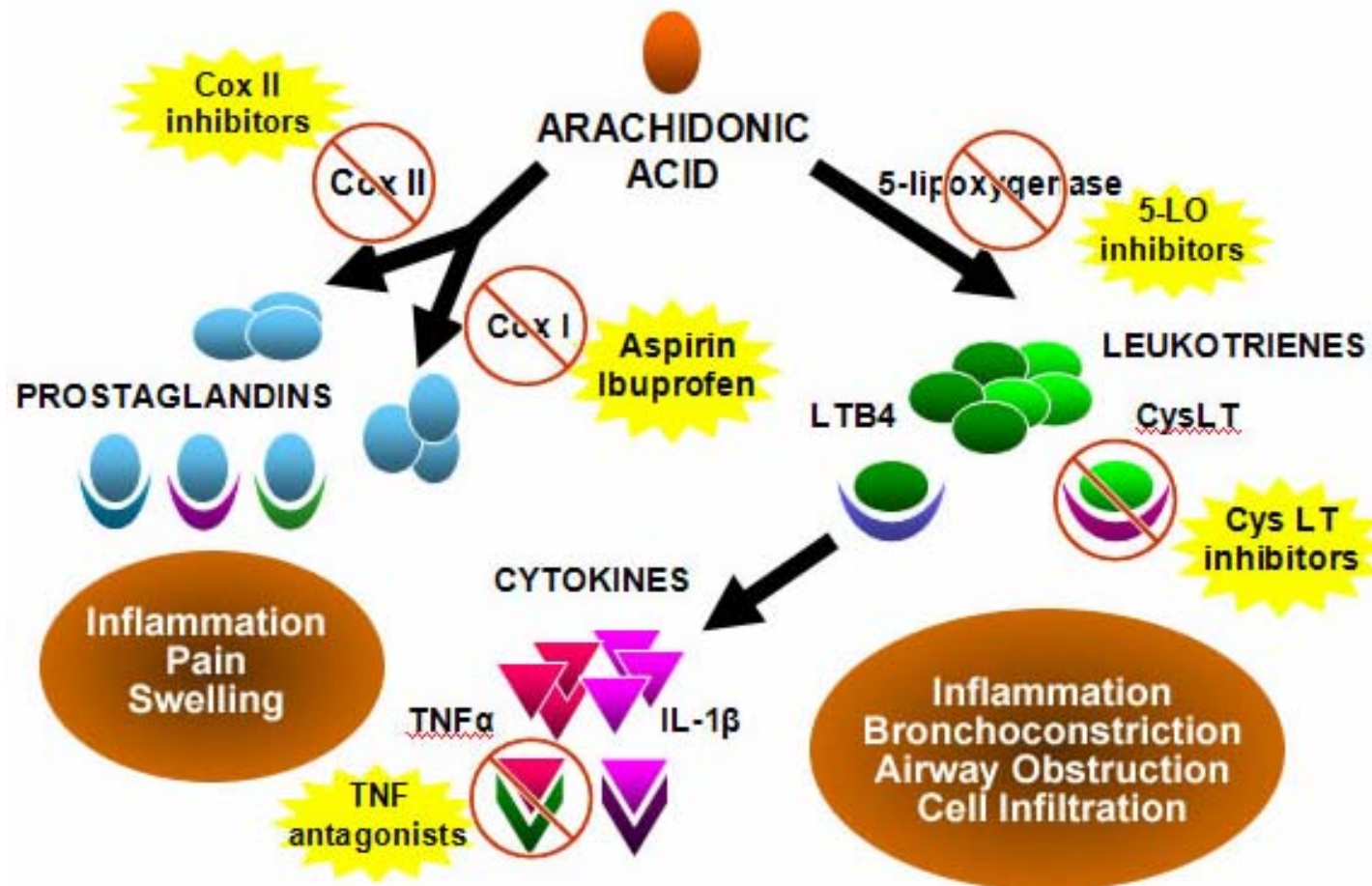

Eicosanoid hormones are derived from PUFAs

- Arachidonic acid (20:4n6) is major precursor of multiple signal molecules:

prostaglandins (PG), prostacyclins, thromboxanes (TX) and leukotrienes (LT)

- PGs = 20 carbon fatty acids containing a 5-carbon ring
- PGs stimulate inflammation, regulate blood flow, control ion transport, modulate synaptic transmission & induce sleep

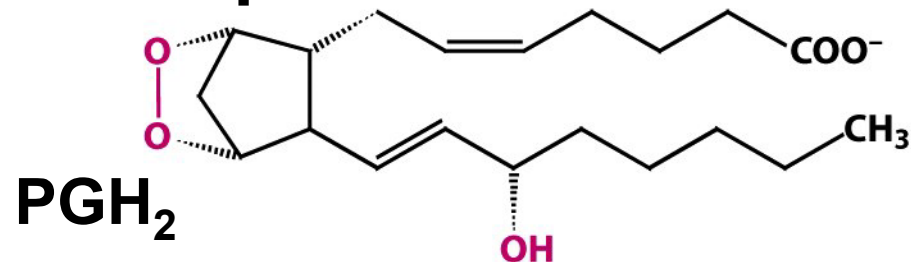

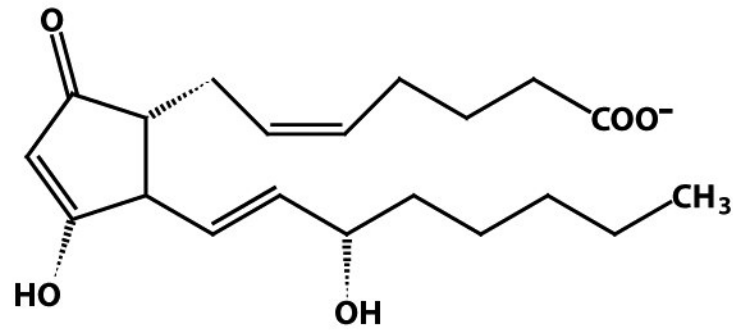

Prostaglandin E₂

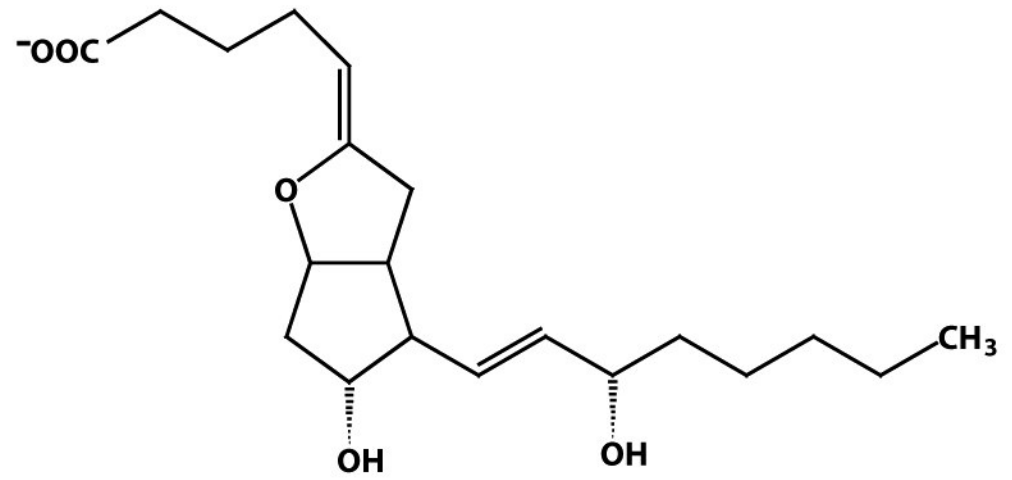

Prostacyclin (PGI₂)

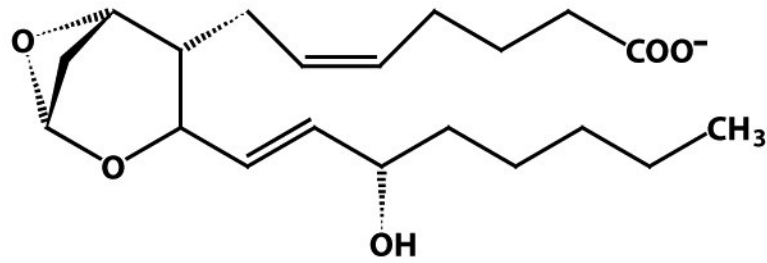

Thromboxane A₂ (TXA₂)

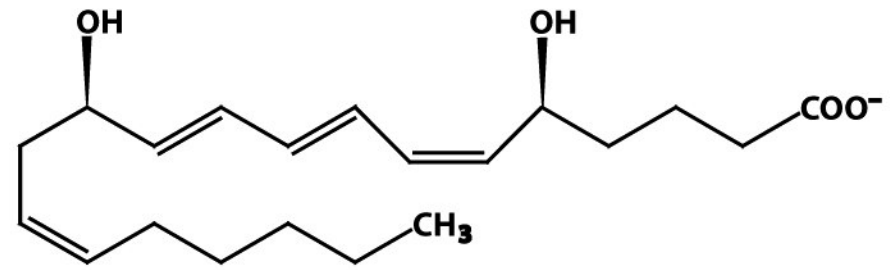

Leukotriene B₄

Importance of eicosanoids

- **Nobel Prize in 1982 for discovery of PG biological role and 1990 for PG synthesis**
- **PGs are found in almost all tissues & organs**
- **Ex of PG antagonists:**
 - NSAIDs (inhibit COX → aspirin, ibuprofen)
 - corticosteroids (inhibit phospholipase A2 production)
- **TXs are vasoconstrictors & hypertensive agent**
 - role in thrombosis (clot in blood vessel)
- **LTs & cysteinyl-LTs important in inflammation**
 - asthma, psoriasis, anaphylaxis & atherosclerosis

Eicosanoid-based medicines

Type	Medical condition
PGI₁ analog	Pulmonary hypertension, avoiding reperfusion injury
PG analog	Glaucoma, ocular hypertension
PG analog	Labor induction
PGE₂	Labor induction
PGI₂ analog	Pulmonary arterial hypertension
PGE₁ analog	Stomach ulcers, labor induction
LT receptor antagonist	Asthma, seasonal allergies
PGI analog	Pulmonary hypertension

Eicosanoids

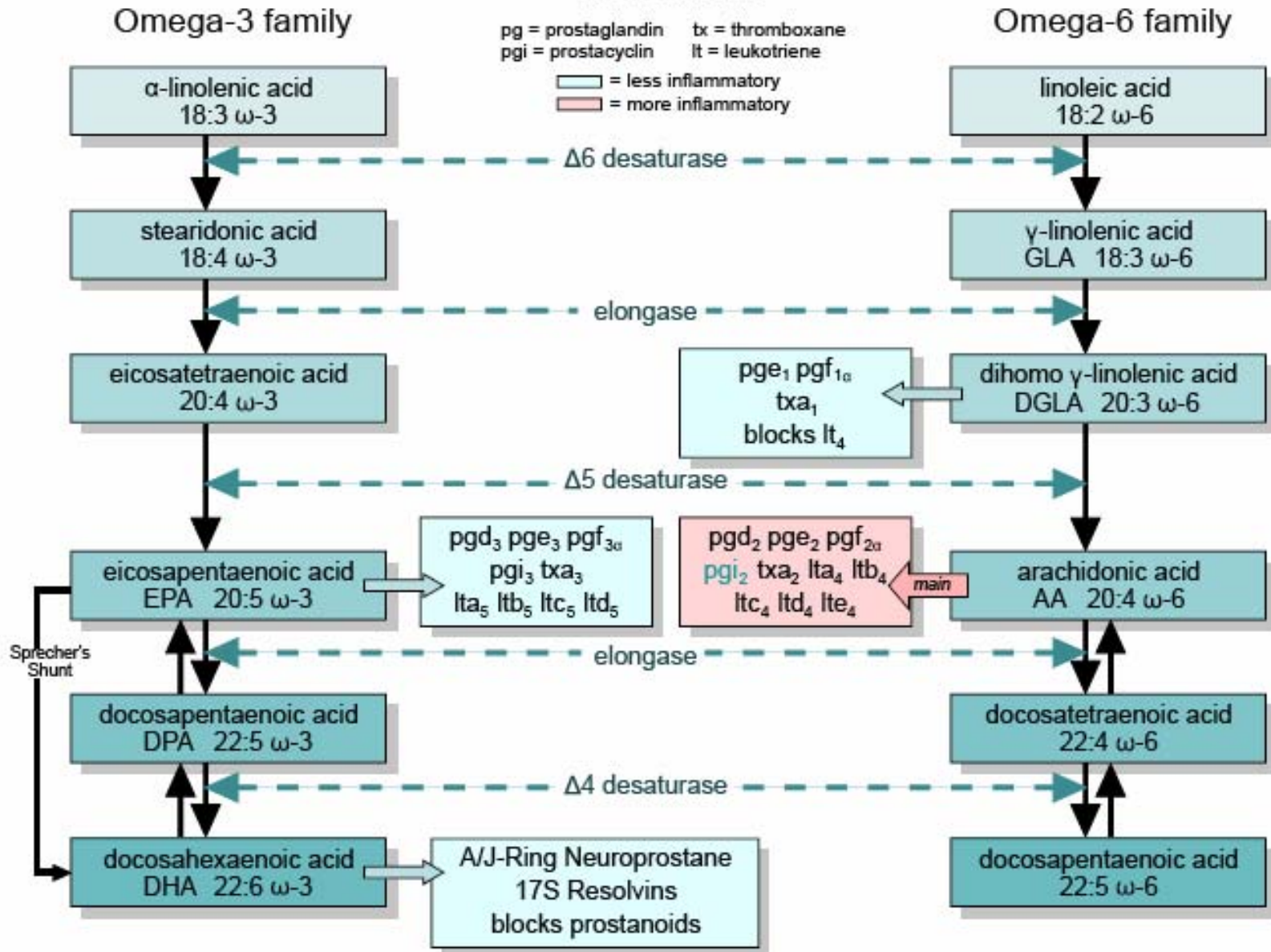

20:4n6 (arachidonic acid)



20:3n6



18:3n6



18:2n6 (linoleic acid)

PGH₂ promotes inflammation and modulates gastric acid secretion

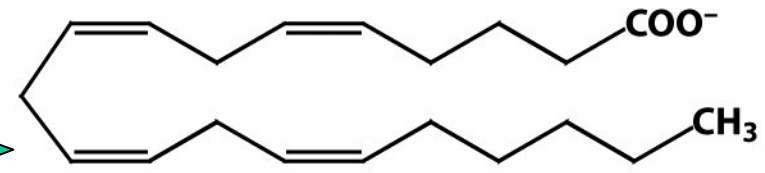

Cyclooxygenase $2 O_2$

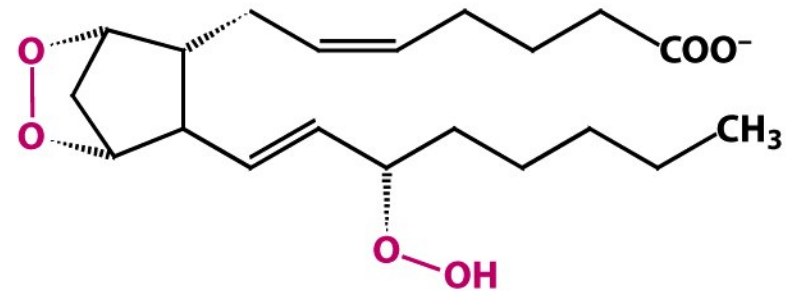

Peroxidase $2 H^+ + 2 e^-$
 H_2O

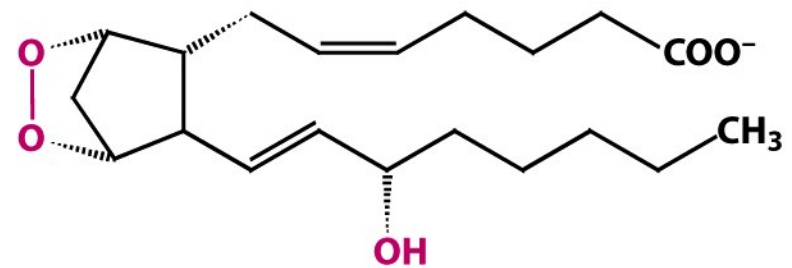

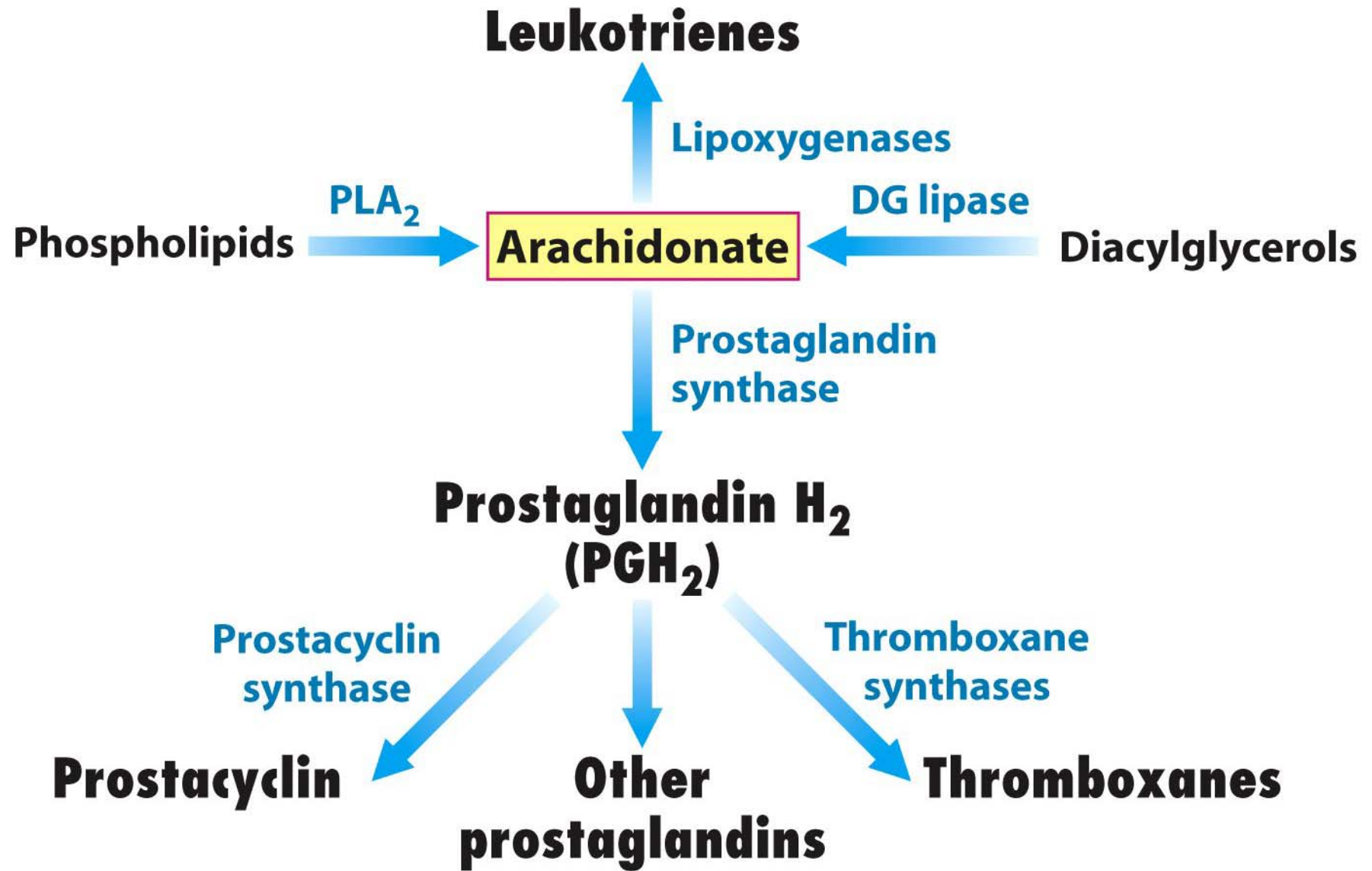

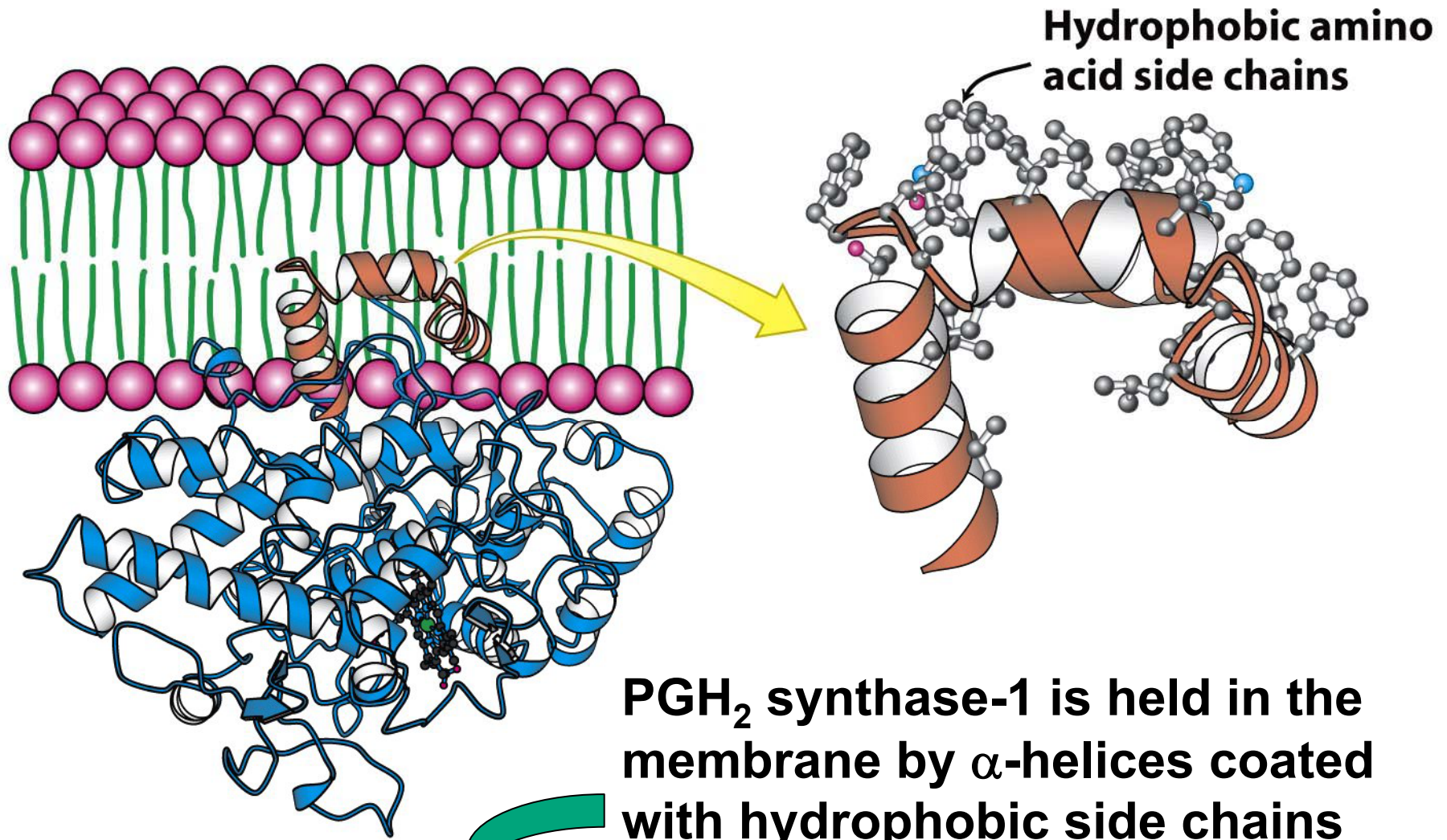

Integral membrane protein

AA is hydrophobic and is funneled thru protein channel

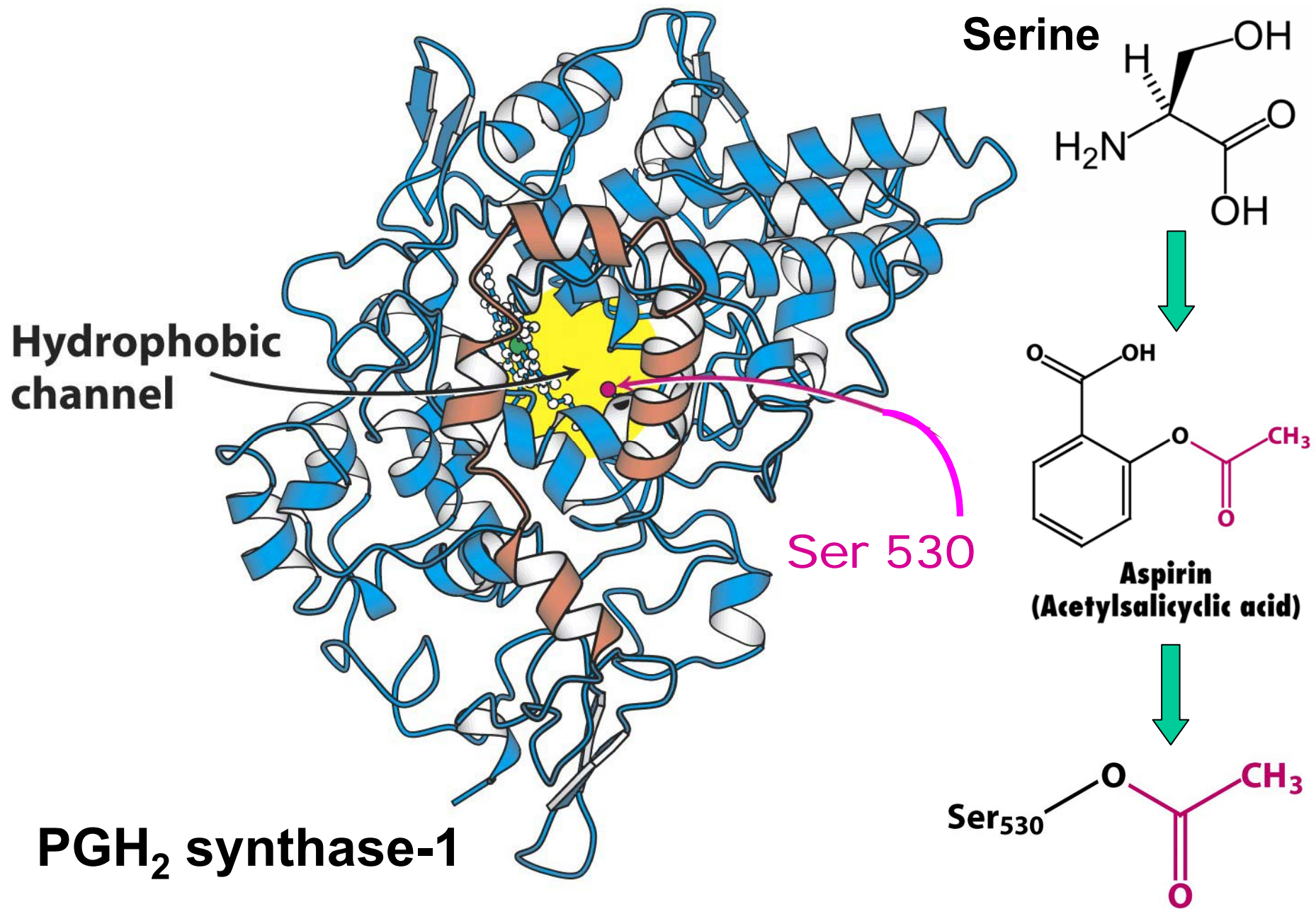

The Arachidonic Acid (AA) Cyclooxygenase (COX) Pathway and Its Products

Inflammatory
Proliferative
Vasoconstrictive
Coagulation

Anti-Inflammatory
Anti-Proliferative
Vasodilatory
Anti-coagulation

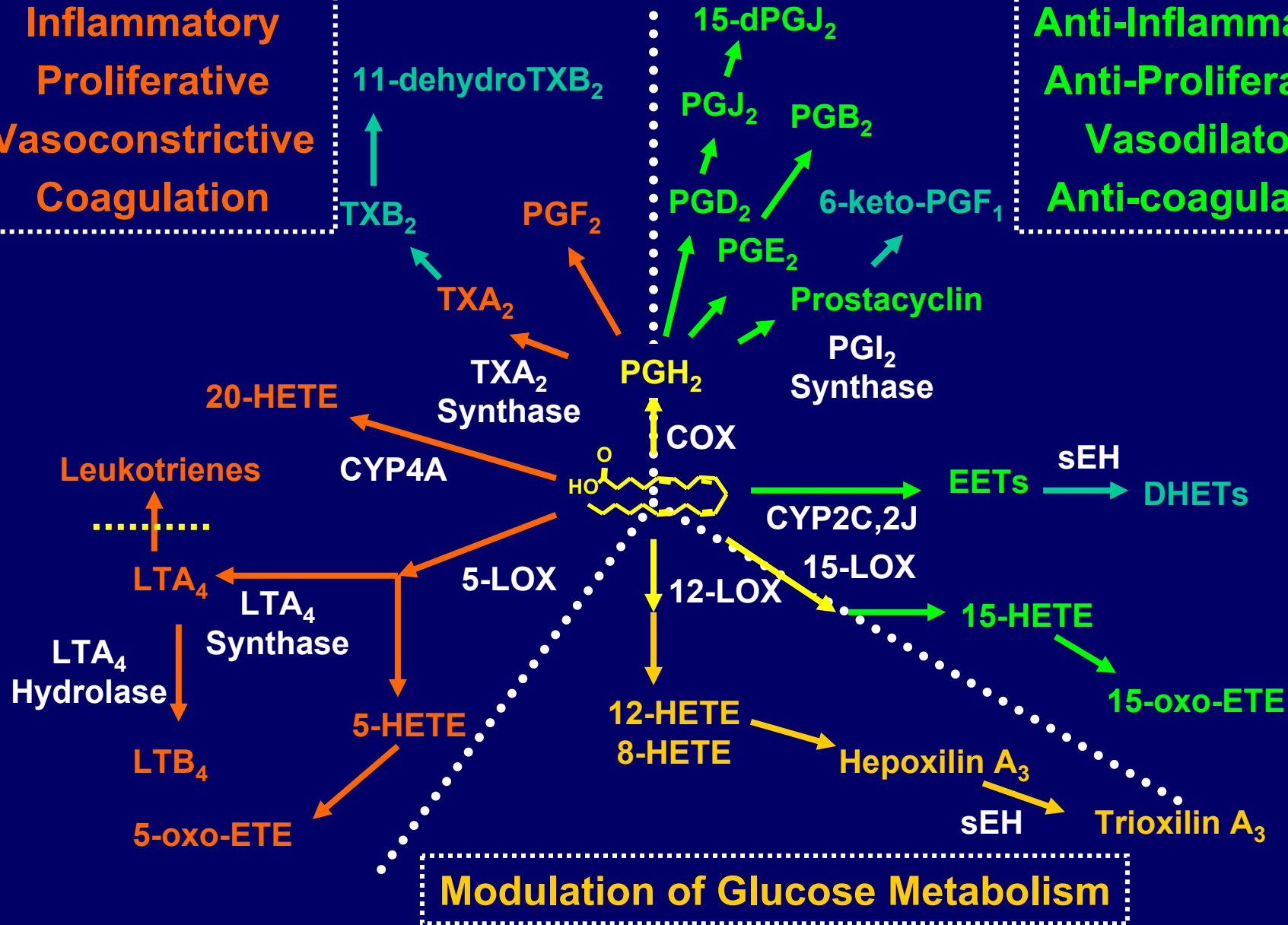

Biosynthesis of membrane lipids and steroids

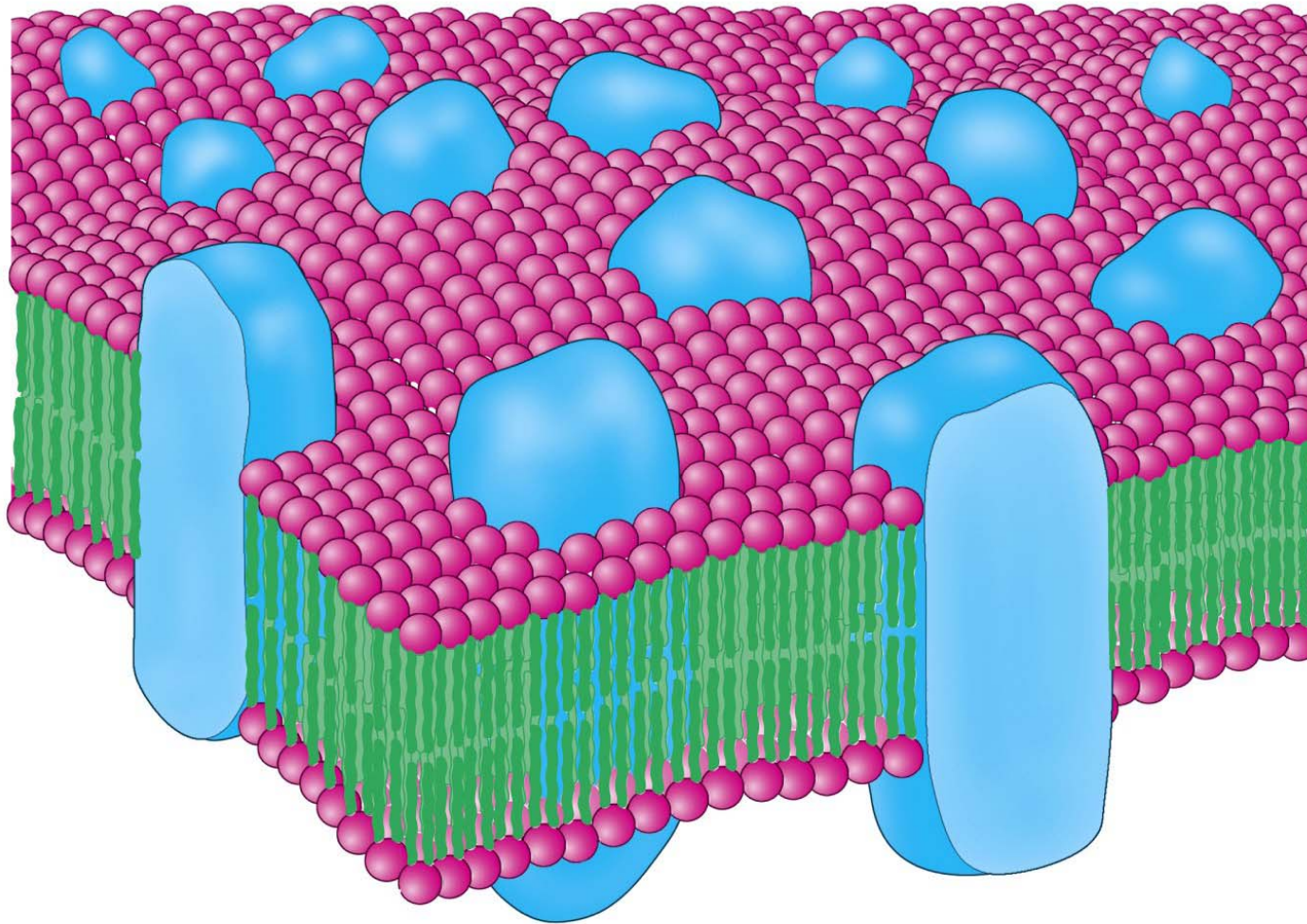

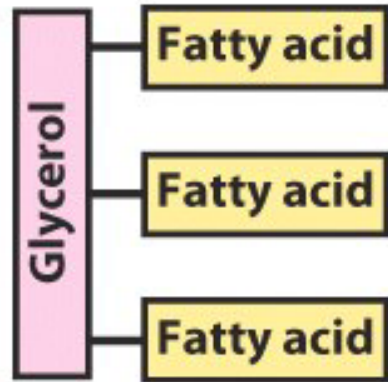

Triacylglycerol (TAG)

= ester of glycerol + 3 FA

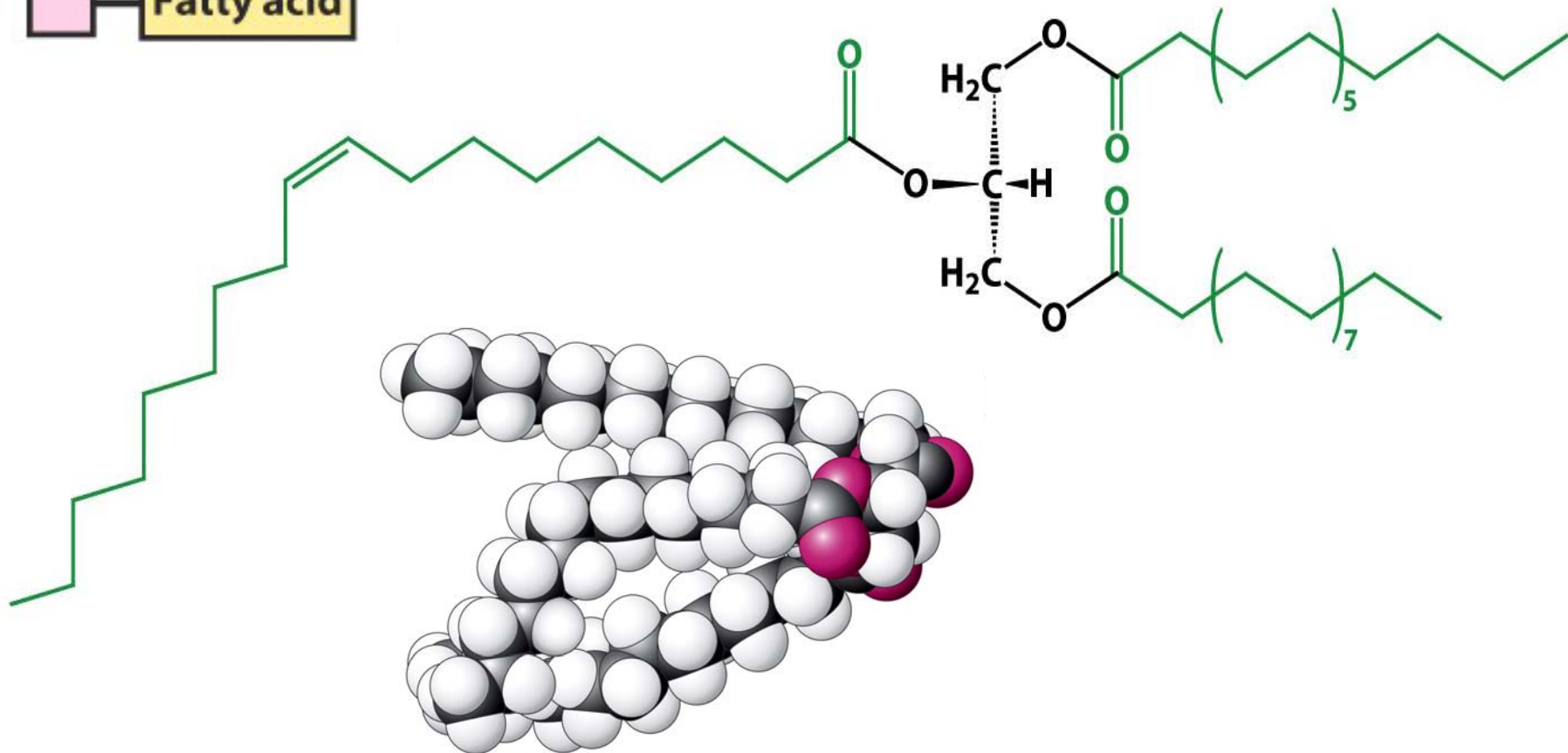

Phospholipids (PL)

major class of membrane lipids

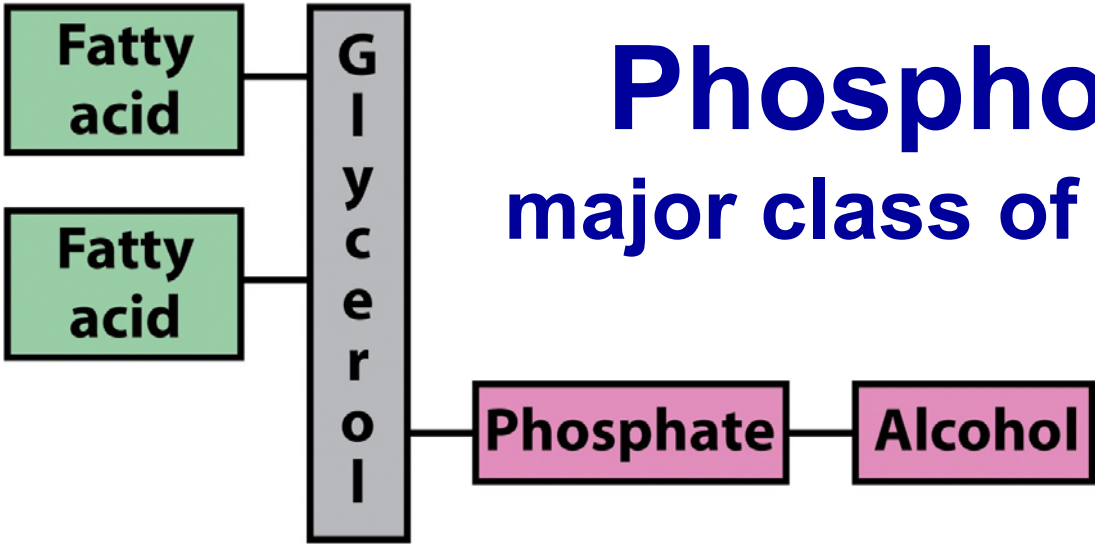

Glycerophospholipid
constructed of 4 components

hydrophobic

hydrophilic

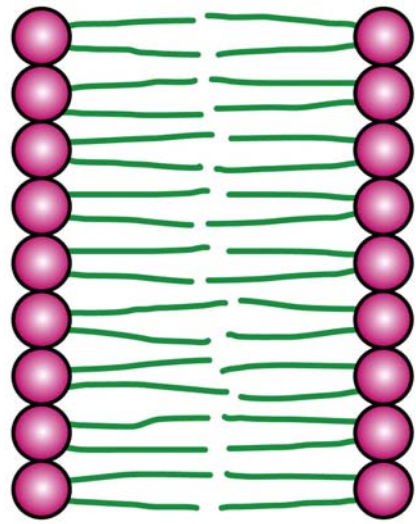
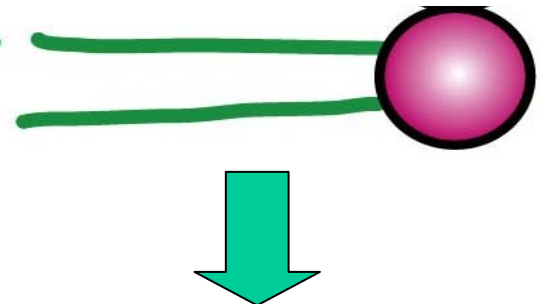
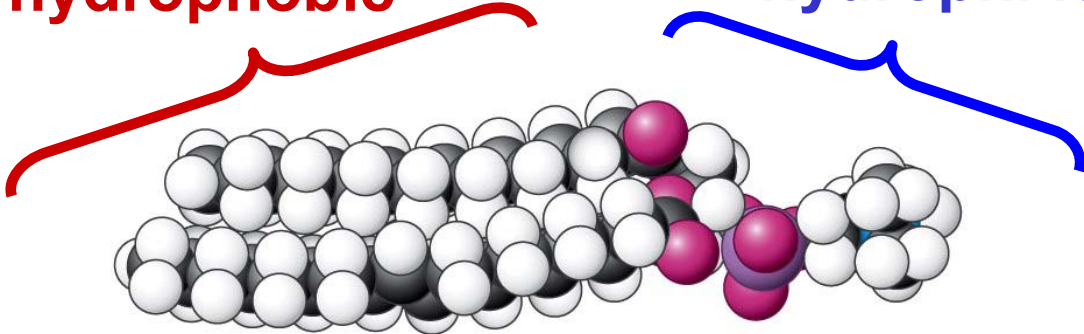

Membrane

1st step in synthesis of phospholipids (PLs) and triacylglycerols (TAGs) is the synthesis of phosphatidate

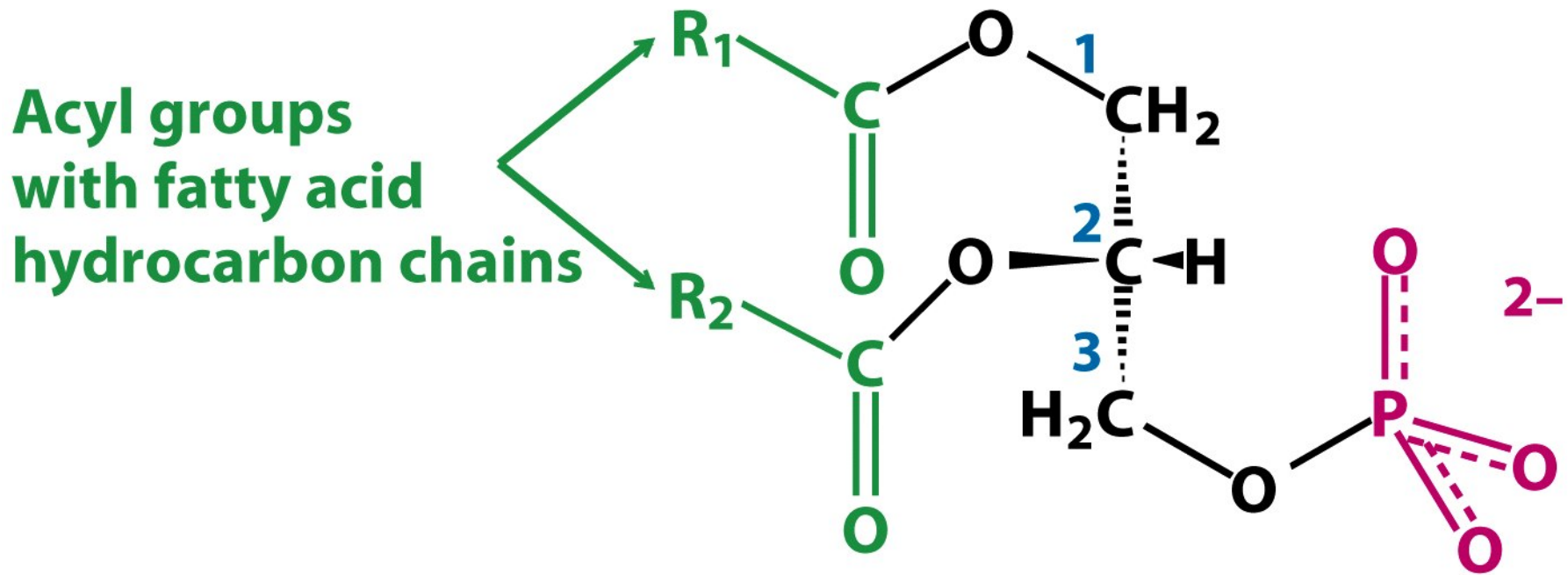

**Phosphatidate
(Diacylglycerol 3-phosphate)**

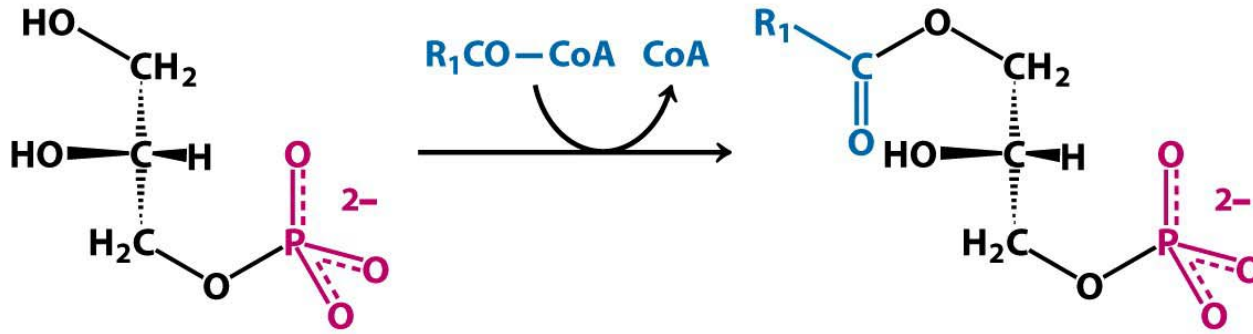

Glycerol 3-phosphate

Lysophosphatidate

**Phosphatidate
is built from
L-glycerol-3-
phosphate and
activated fatty acids**

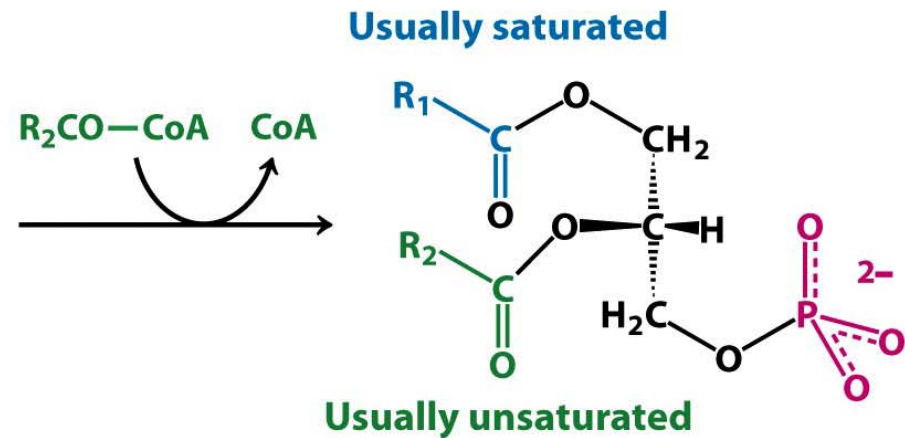

Phosphatidate

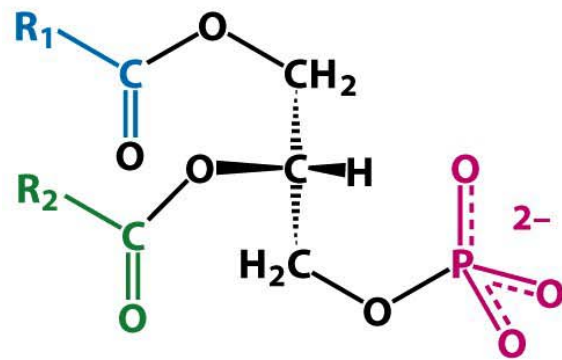

Phosphatidate

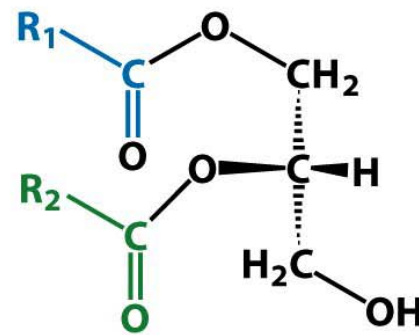
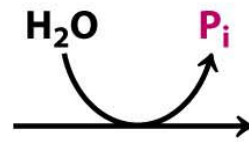

Diacylglycerol (DAG)

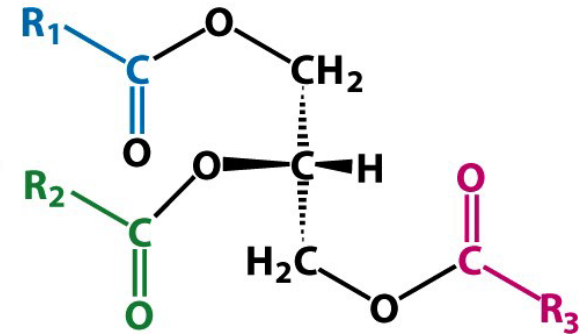
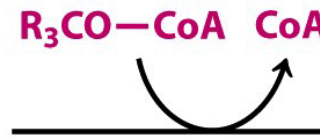

Triacylglycerol

**TAG synthesis
proceeds via DAG**

Triacylglycerols (TAG)

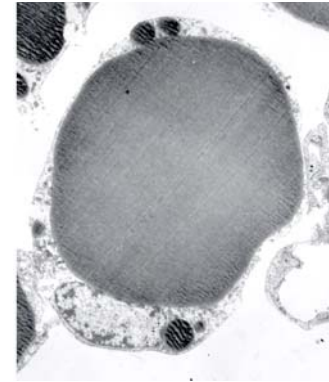

- **Stored energy in fat cells**
 - adipose cells
 - **More energy/gram than carbohydrates**
 - 9 kcal/g compared to 4 kcal/g
 - stored in anhydrous form (carbs 2g H₂O/g)
- => fat has 6.75x > energy than hydrated glycogen**

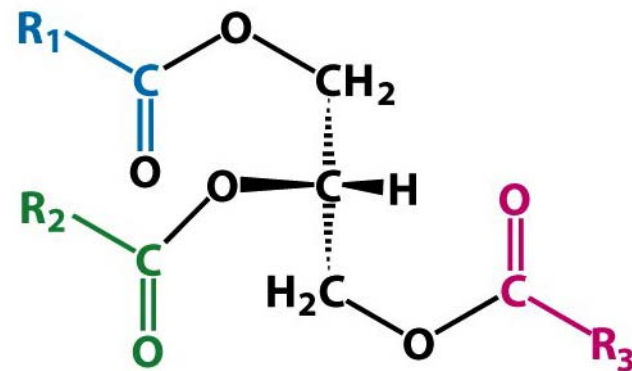
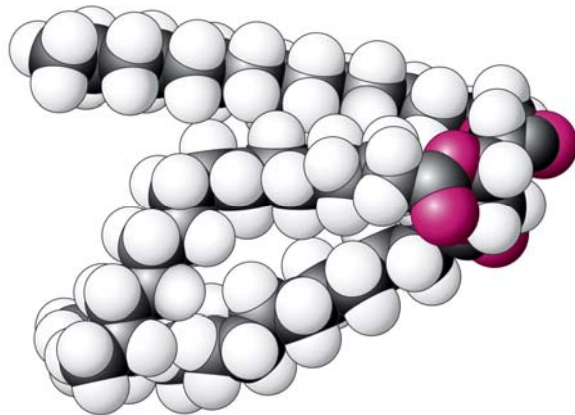

TAG cycle

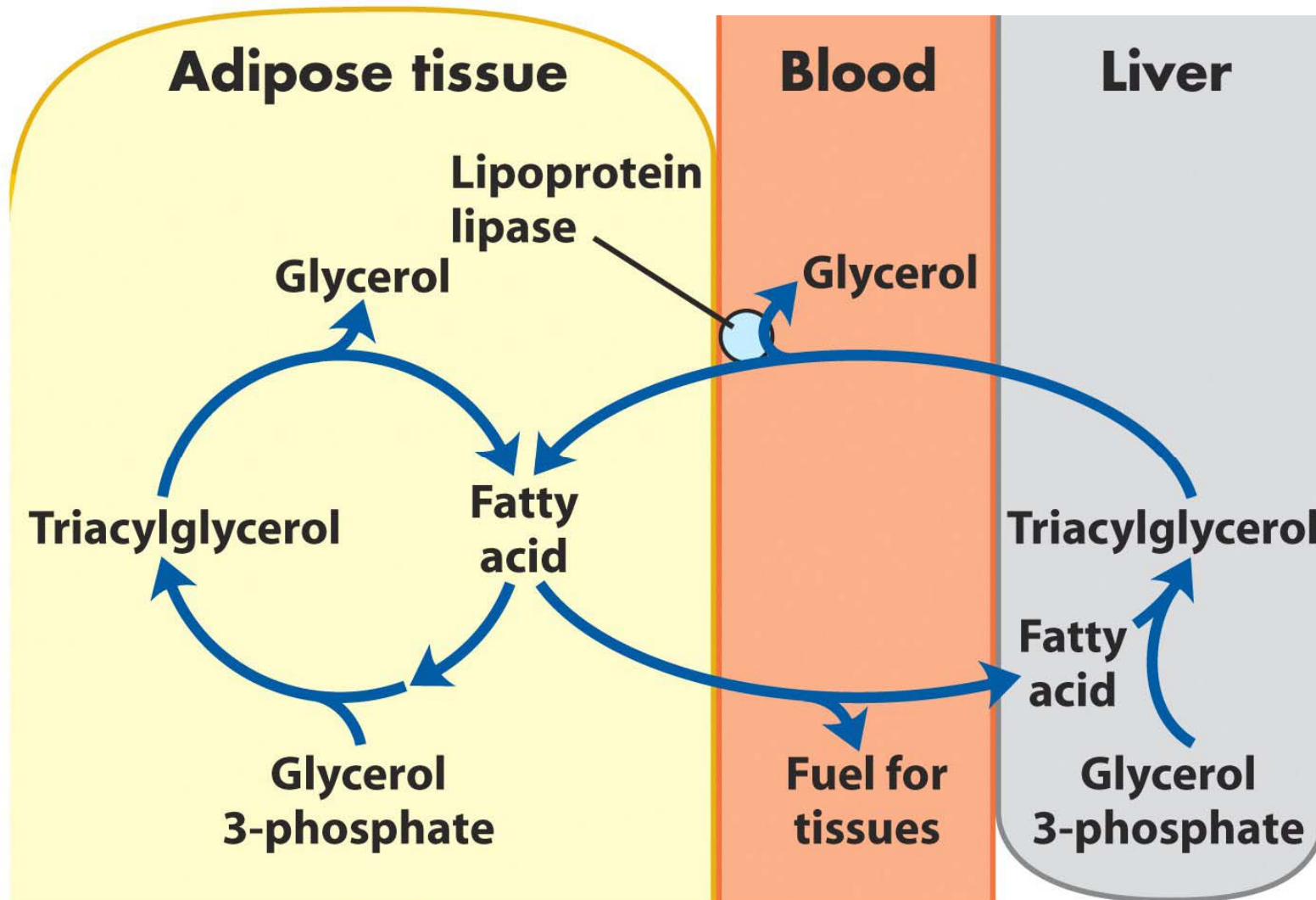

Glycerophospholipids (phosphoglycerides)

- glycerol-based PLs – main component of biological membranes

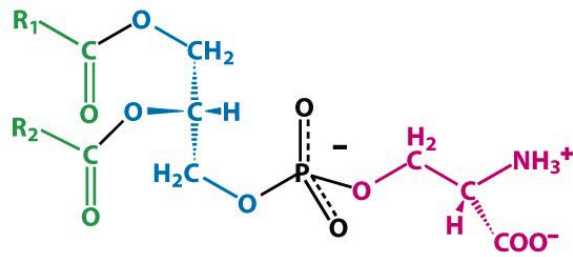

Phosphatidylserine

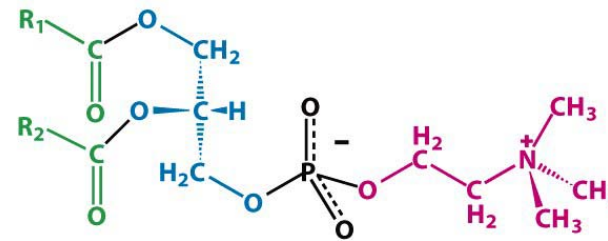

Phosphatidylcholine

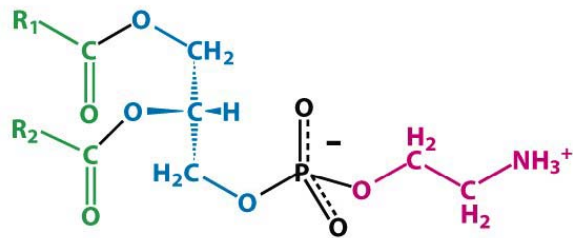

Phosphatidylethanolamine

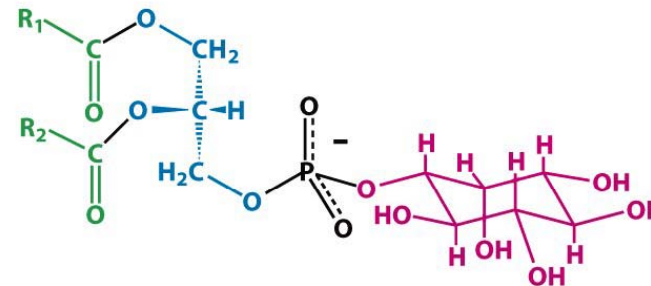

Phosphatidylinositol

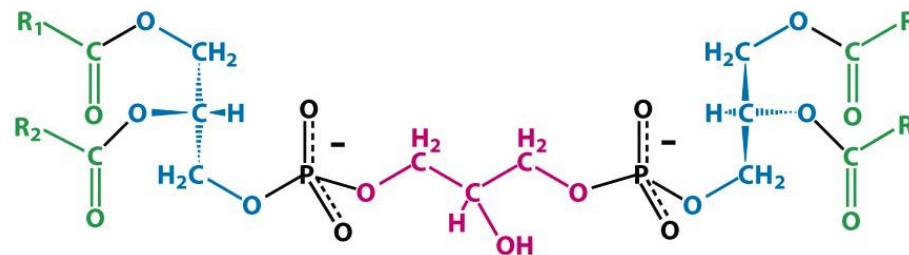

Diphosphatidylglycerol (cardiolipin)

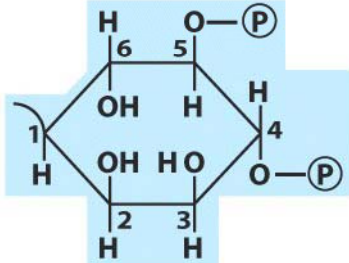
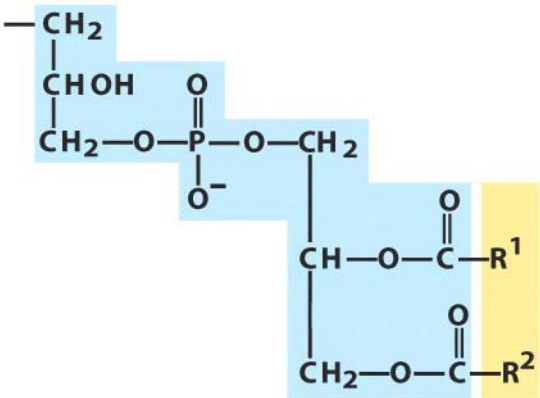
	Name of glycerophospholipid	Name of X	Formula of X	Net charge (at pH 7)
PA	Phosphatidic acid	—	— H	- 1
PE	Phosphatidylethanolamine	Ethanolamine	— CH ₂ —CH ₂ —NH ₃ ⁺	0
PC	Phosphatidylcholine	Choline	— CH ₂ —CH ₂ —N ⁺ (CH ₃) ₃	0
PS	Phosphatidylserine	Serine	— CH ₂ —CH—NH ₃ ⁺ COO ⁻	- 1
PG	Phosphatidylglycerol	Glycerol	— CH ₂ —CH—CH ₂ —OH OH	- 1
PIP₂	Phosphatidylinositol 4,5-bisphosphate	<i>myo</i> -Inositol 4,5-bisphosphate		- 4
CL	Cardiolipin	Phosphatidyl-glycerol		- 2

Biological role of PLs

- **PC most common lipid in mammals**
- **PS is 10% of total PLs in mammals**
- **CL located in inner mitochondrial membrane (role in oxidative phosphorylation)**
- **Ampipathic = possesses both hydrophilic and hydrophobic properties**

PL synthesis requires an activated intermediate

Strategy 1

Alcohol activation of CDP

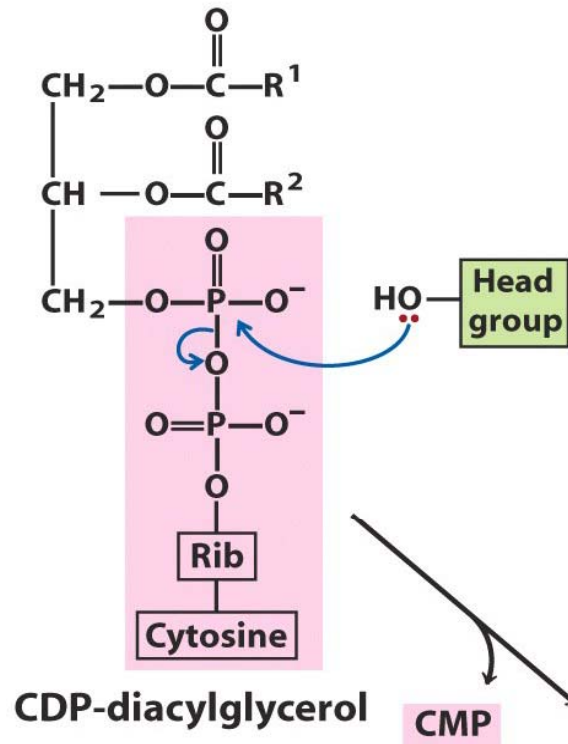

Glycerophospholipid

CDP=cytidine diphosphate

Strategy 2

DAG activation of CDP

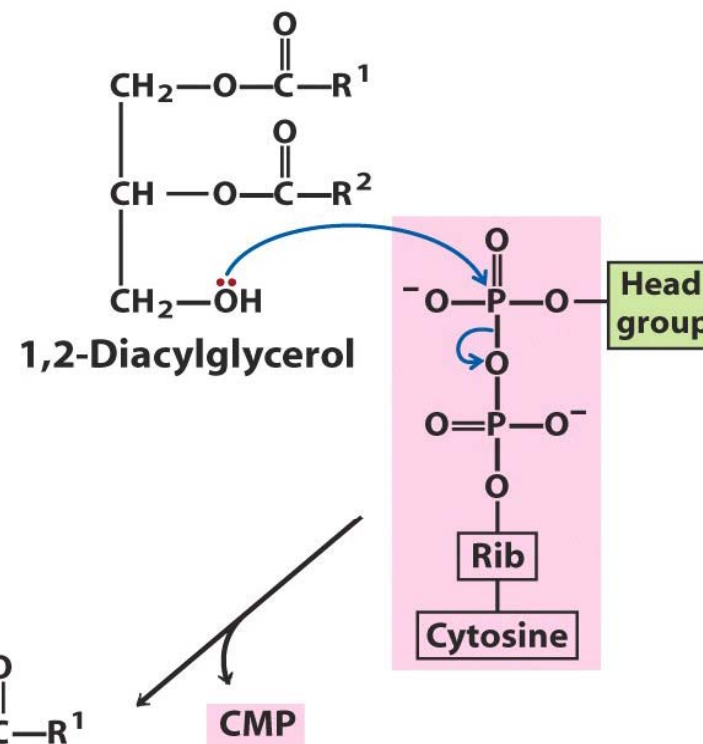

Head group

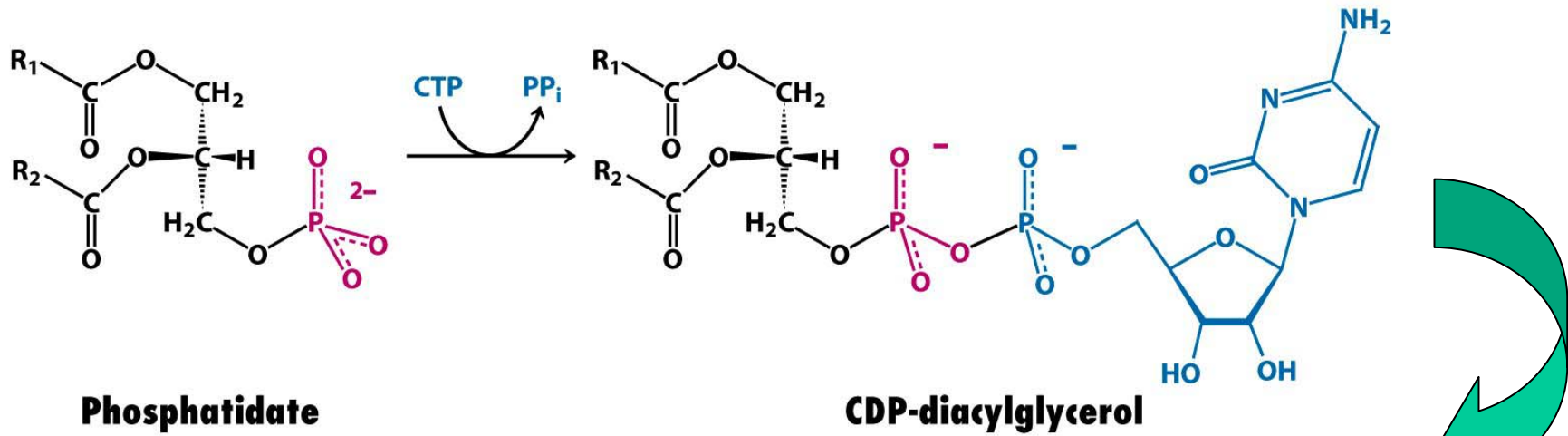

Strategy 1

PL synthesis from activated alcohol

CDP=cytidine diphosphate

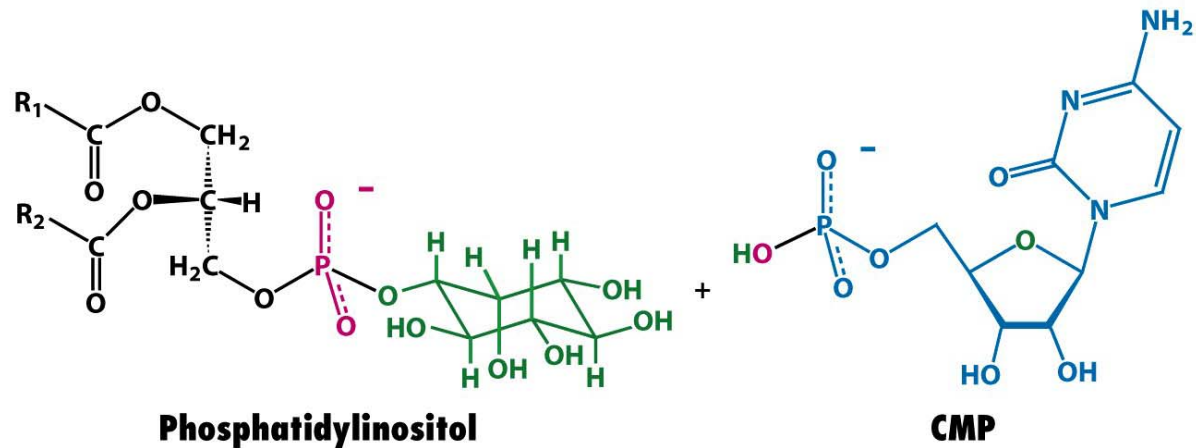
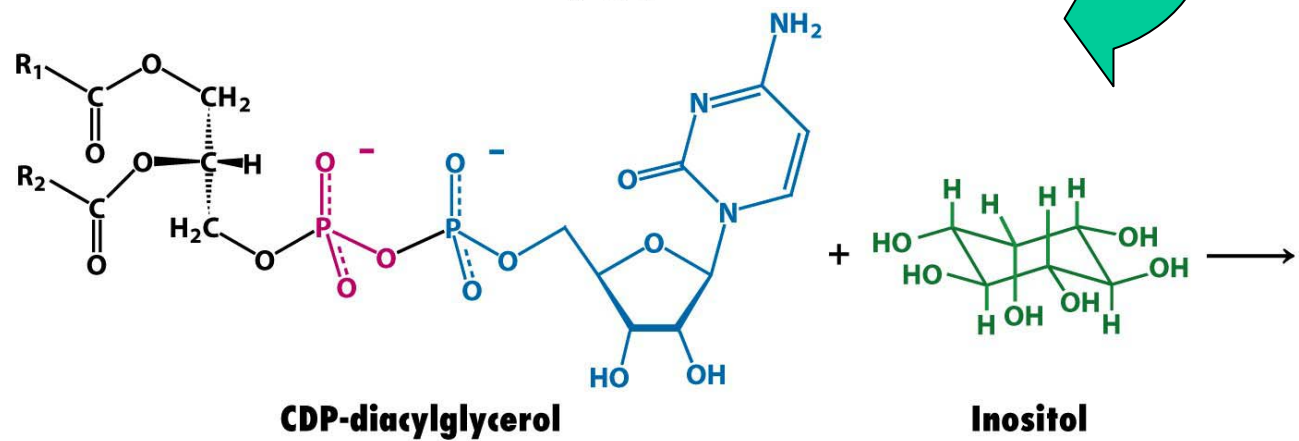

Strategy 2

PL synthesis from activated DAG

CTP=cytidine triphosphate

CDP=cytidine diphosphate

CMP=cytidine monophosphate

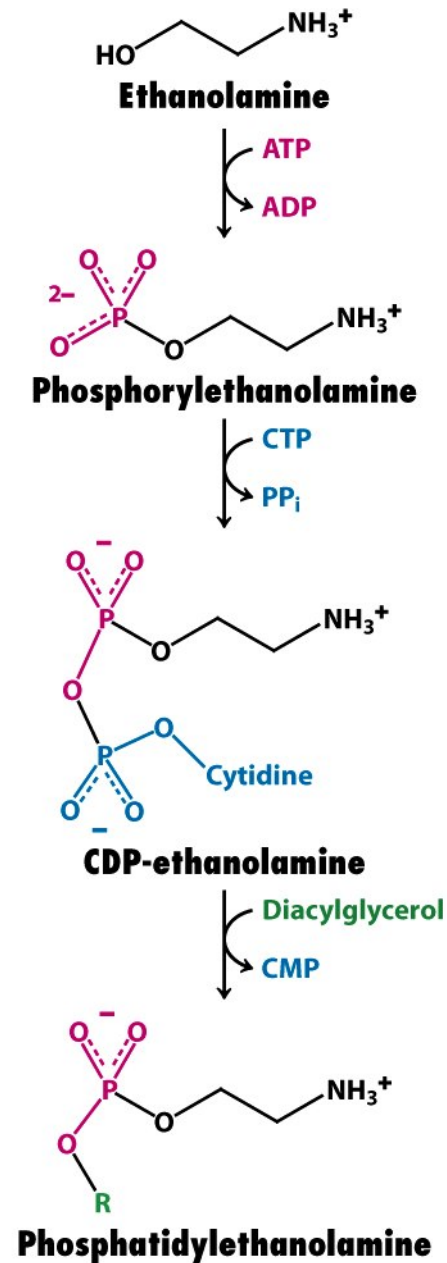

Glycerophospholipid synthesis

PE and PC: **Strategy 1**

PI, PG, cardiolipin (CL): **Strategy 2**

PS, PE, PC are “**coupled**”

PS from PE or PC

PC from PE (+ 3 adoMet)

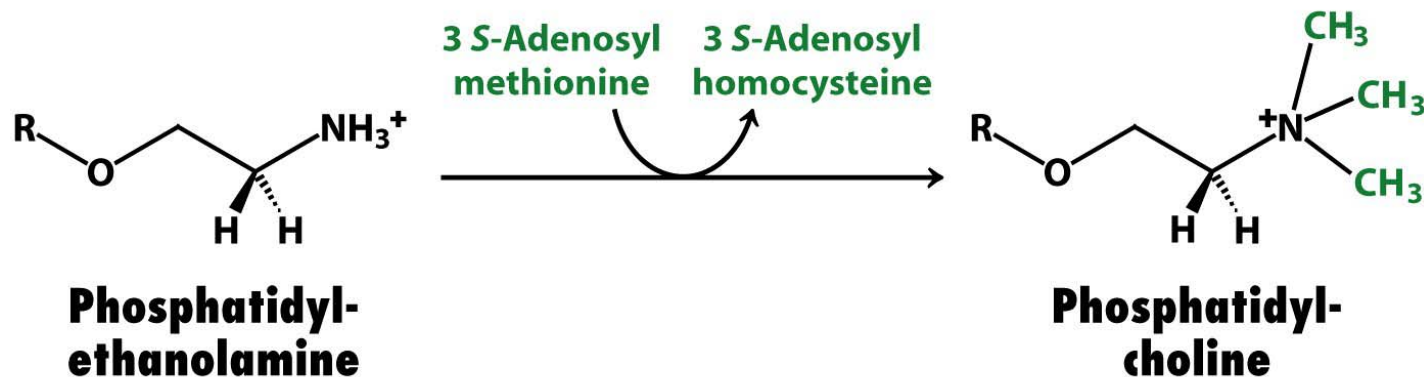

Sphingolipids

contain sphingosine backbone (not glycerol)



Sphingosine

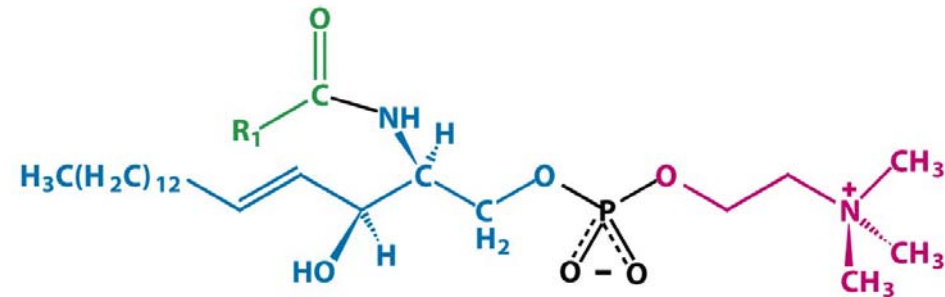
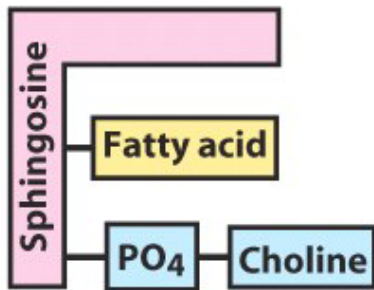

Sphingomyelin

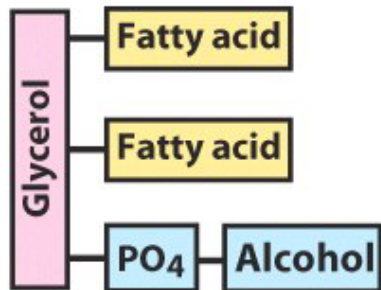

glycerophospholipid

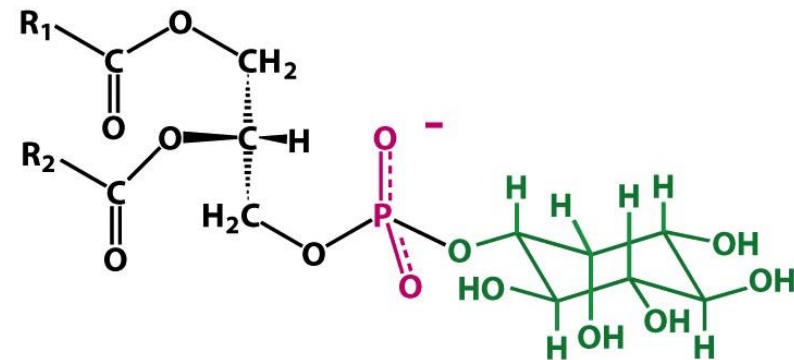

Phosphatidylinositol

Membrane lipid = concentration ↑ in central nervous system

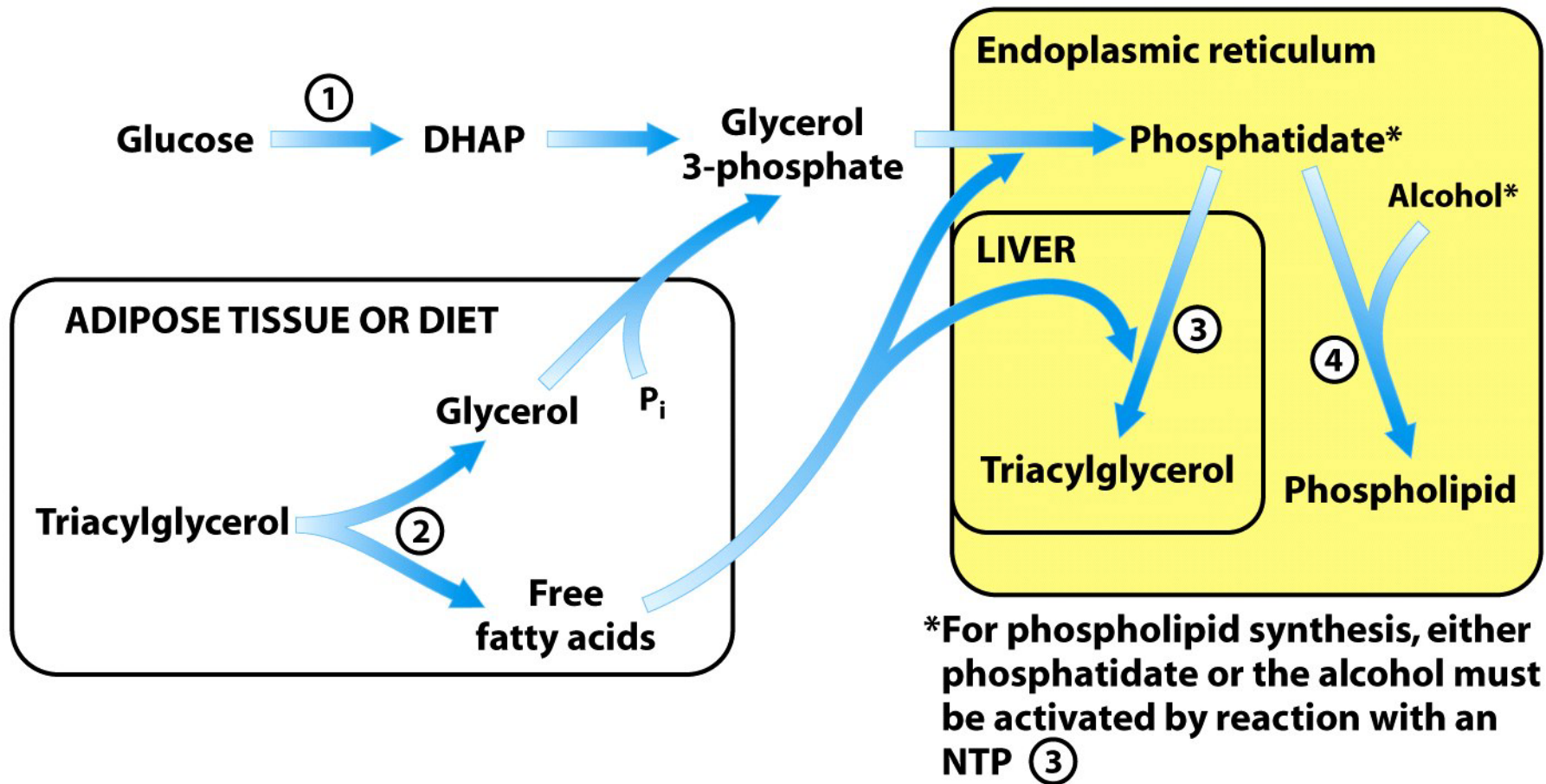

Pathway integration for TAG and PL synthesis
 phosphatidate is produced from multiple pathways
 and is further incorporated into TAGs or PLs

Cholesterol biosynthesis

modulates fluidity in animal membranes
and is precursor of steroid hormones

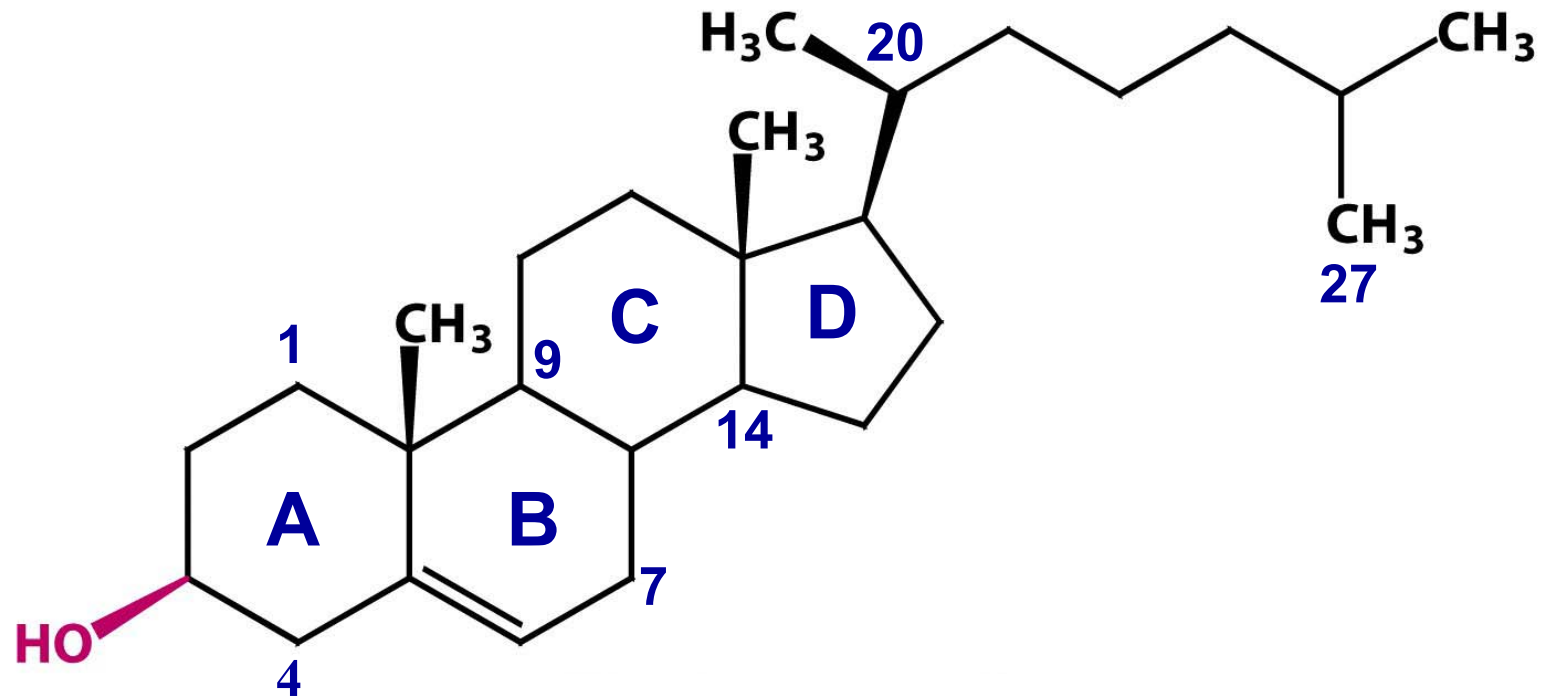

In 4 steps

where **isoprene** is the key intermediate

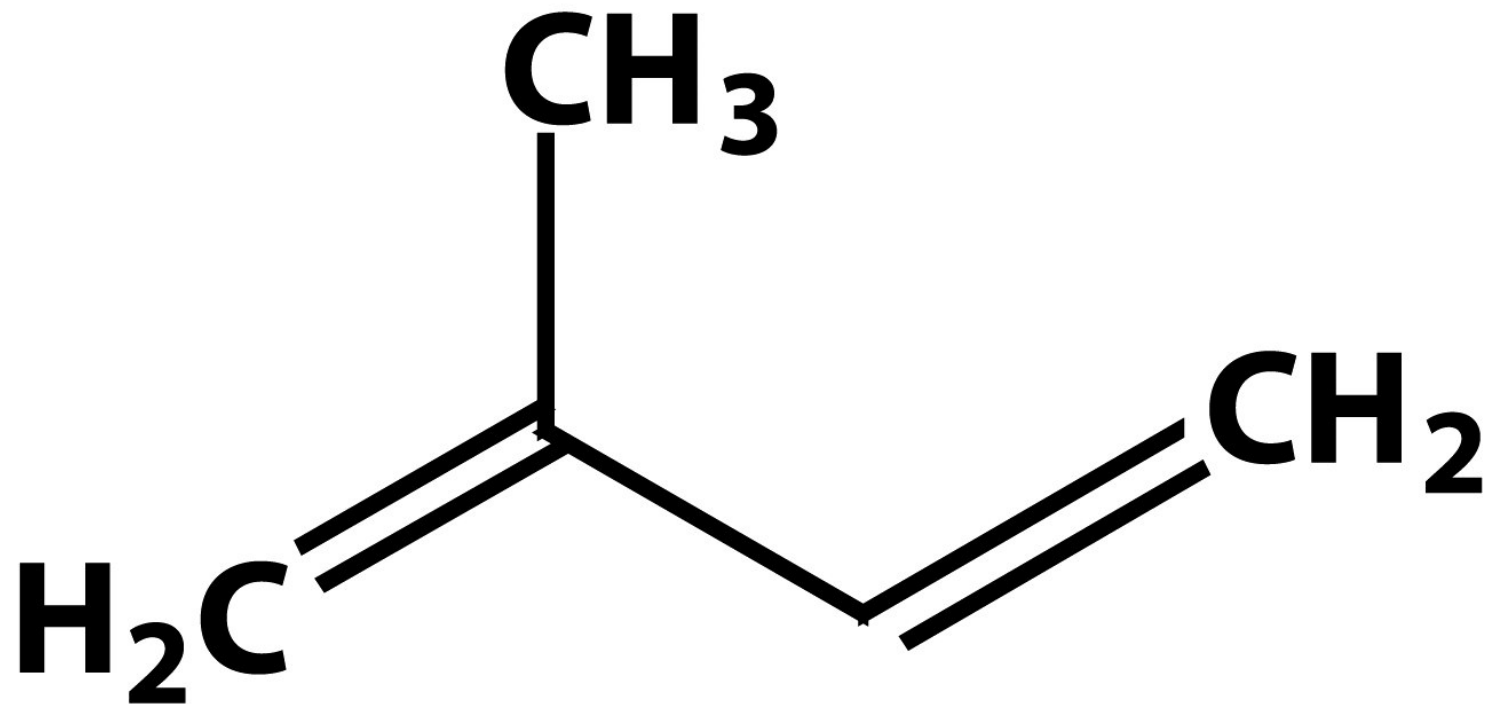

Isoprene

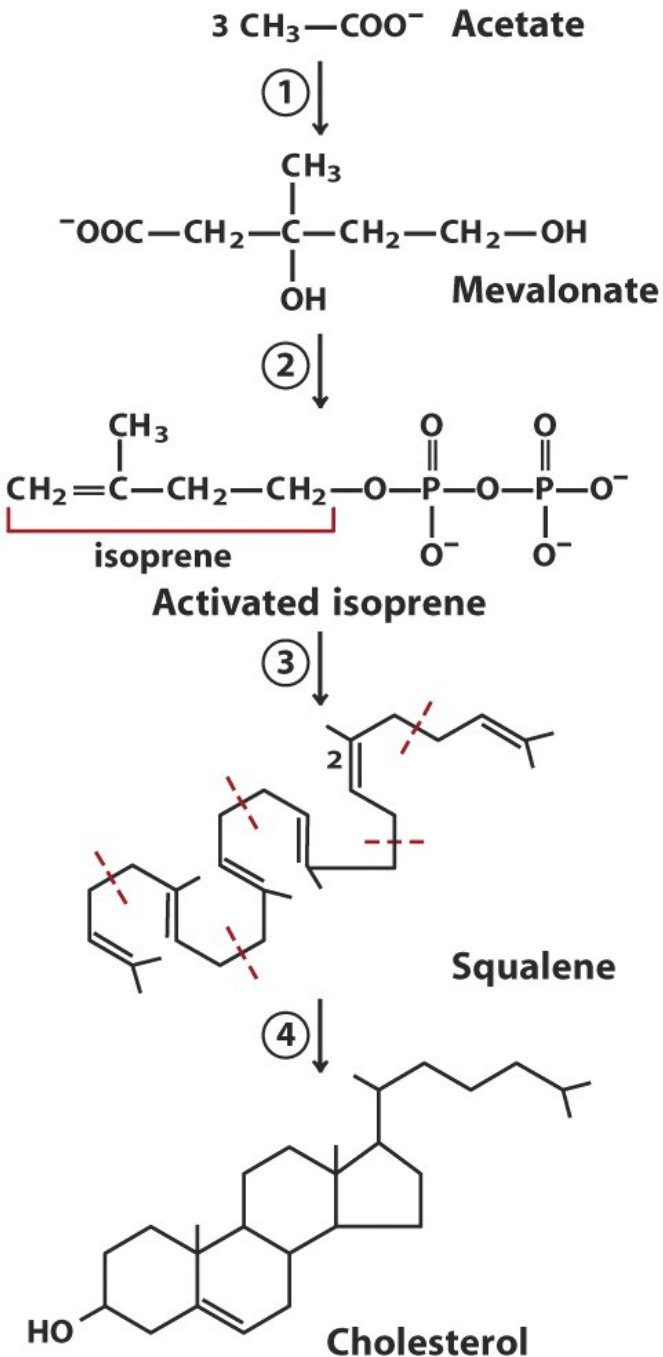

1. Condensation of 3 Ac-CoA to mevalonate

2. Conversion of mevalonate to activated isoprene (3-isopentenyl pyrophosphate)

3. Condensation of 6 activated isoprene units to squalene

4. Cyclization

Step 1: Condensation of 3 Ac-CoA to mevalonate (6 carbons)

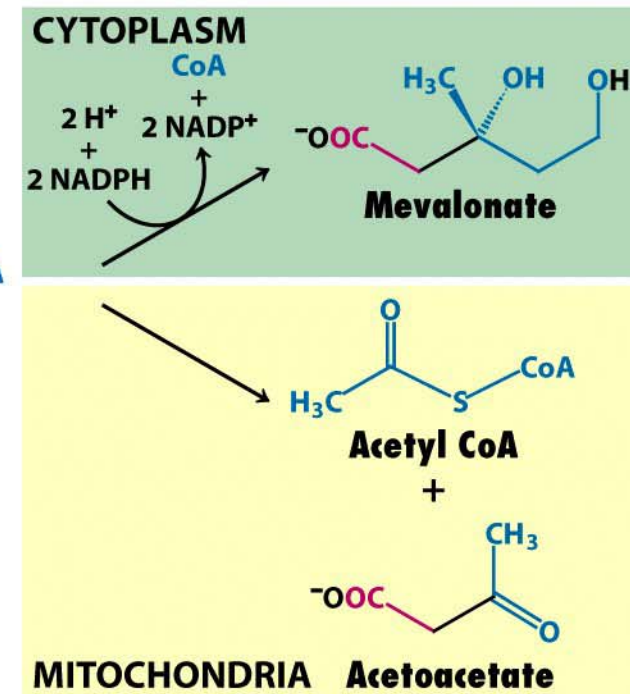
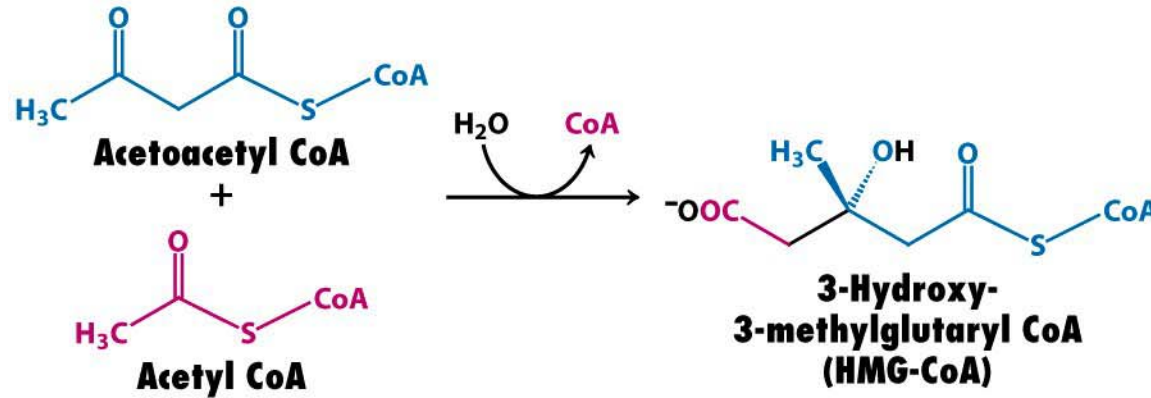

Step 2: Conversion of mevalonate to activated isoprenes (5 carbons)

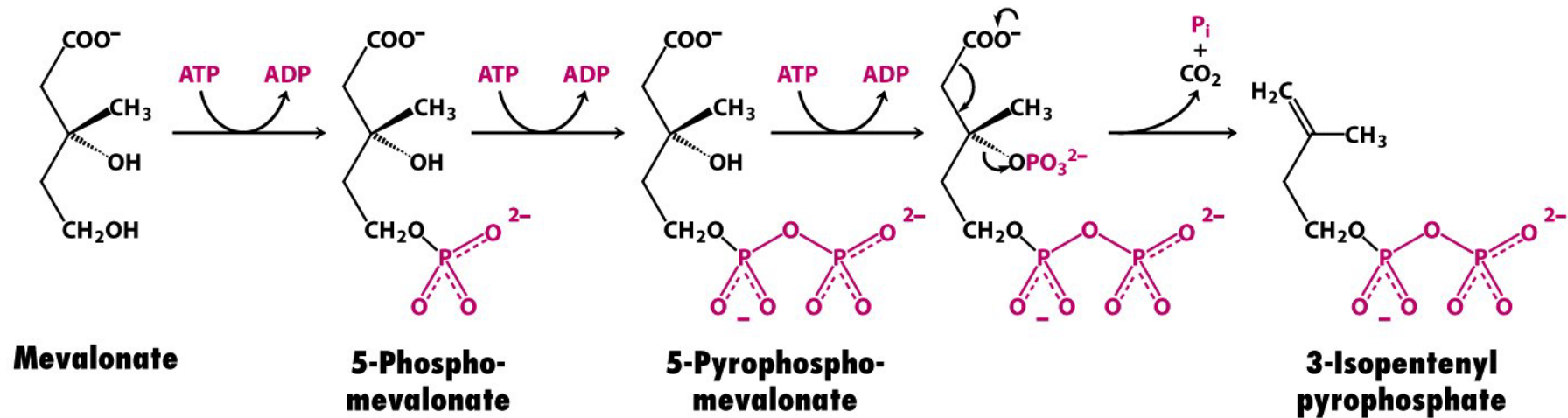

Step 3: Cond. of isoprene- units to squalene (linear, 30 carbons)

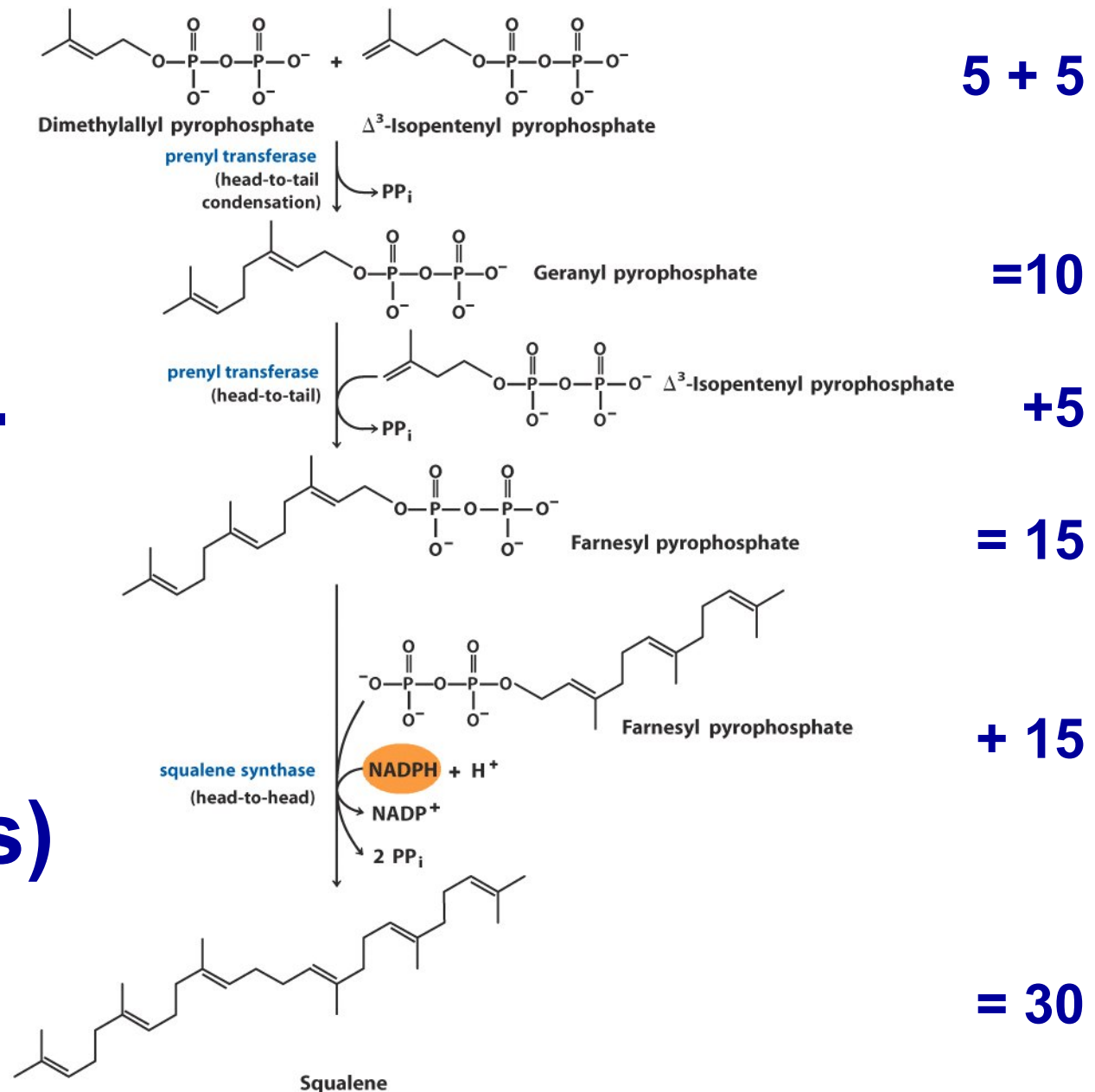

Step 4: Cyclization (4 rings)

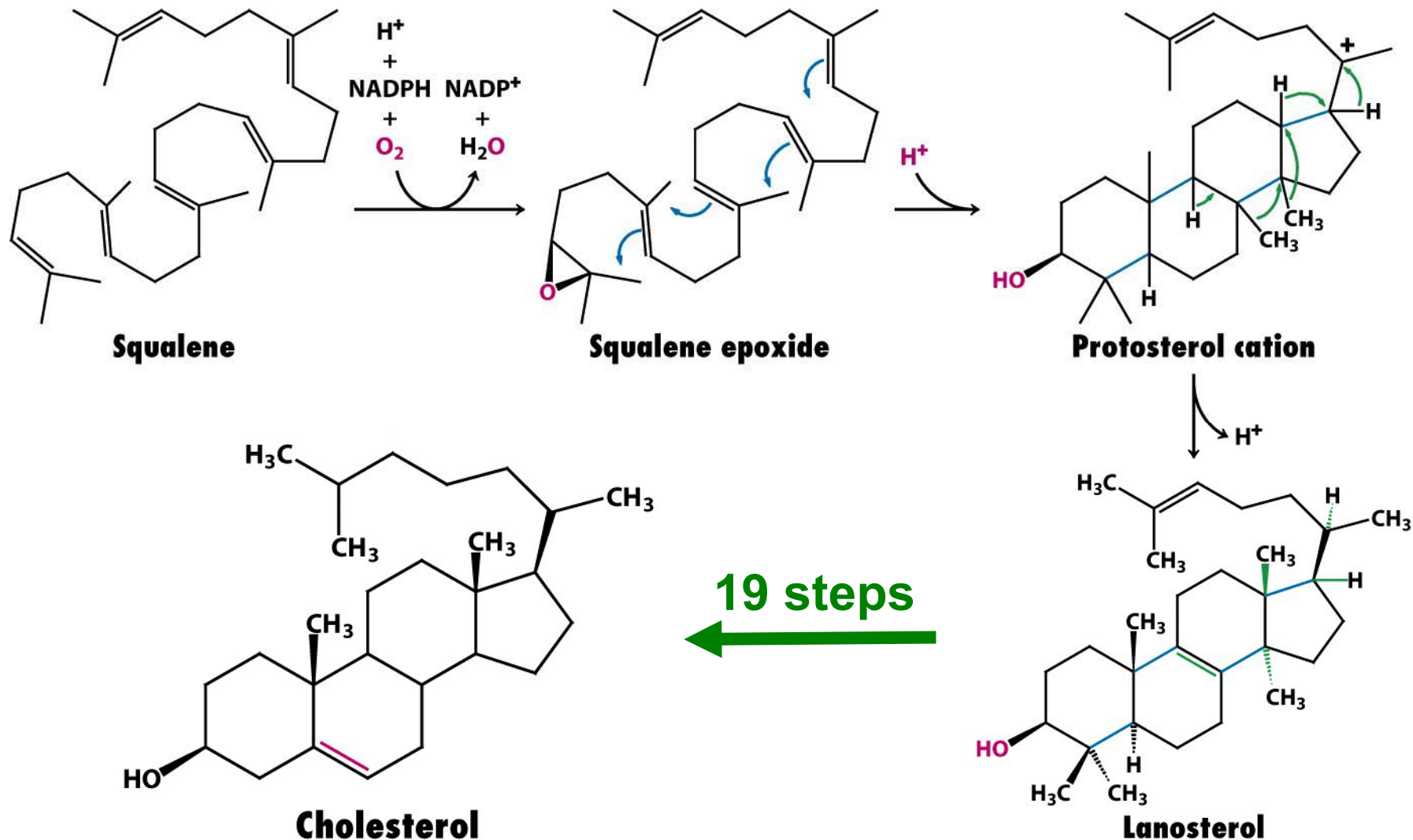

All 27 carbons in cholesterol are derived from Ac-CoA

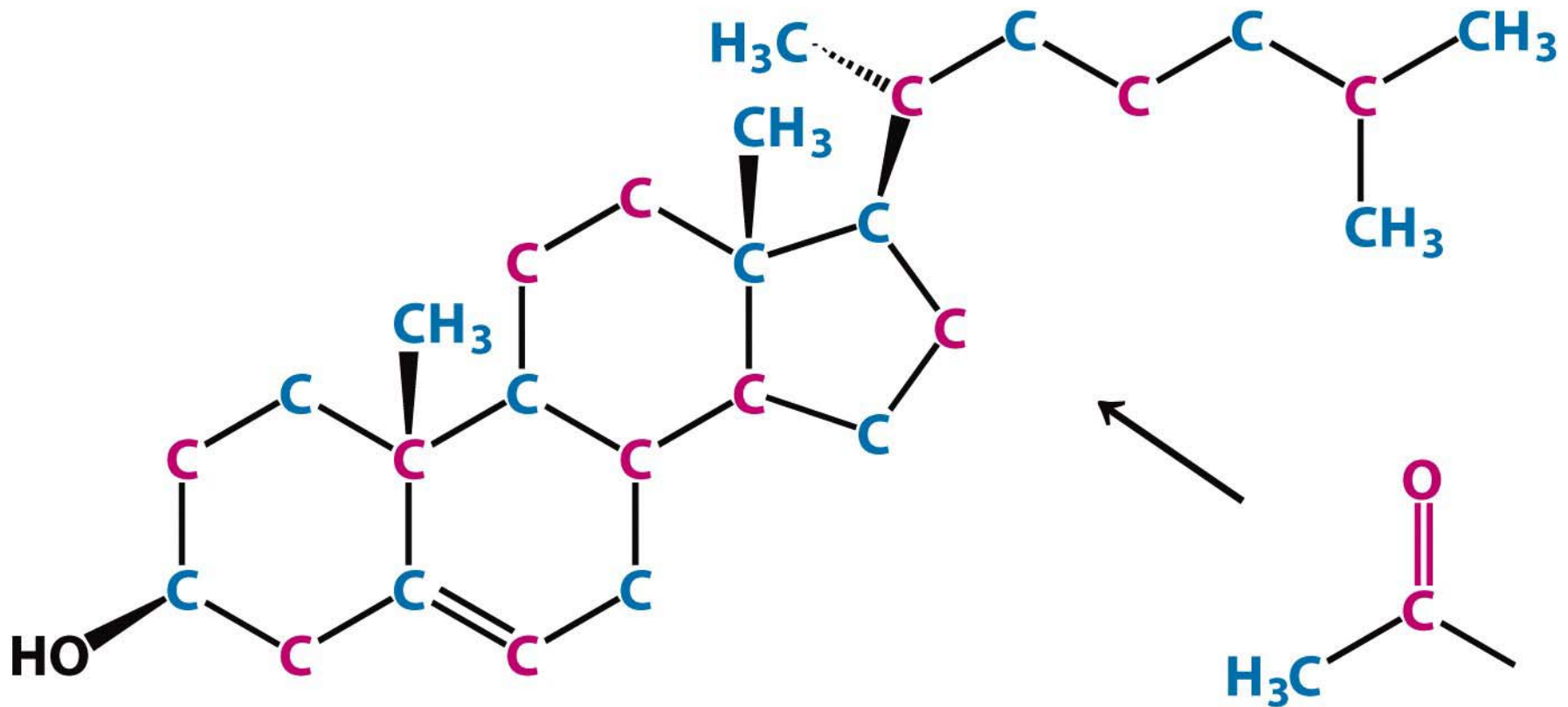

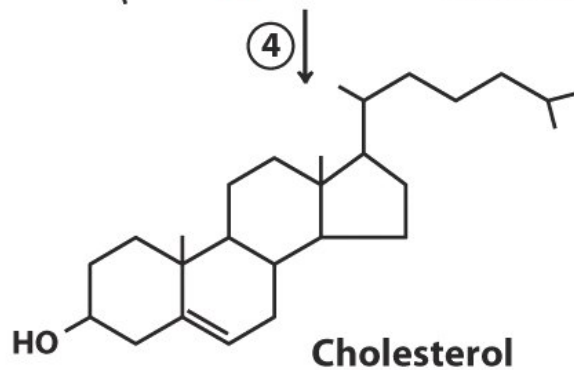
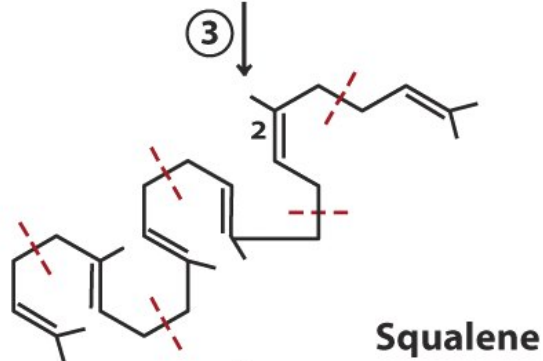
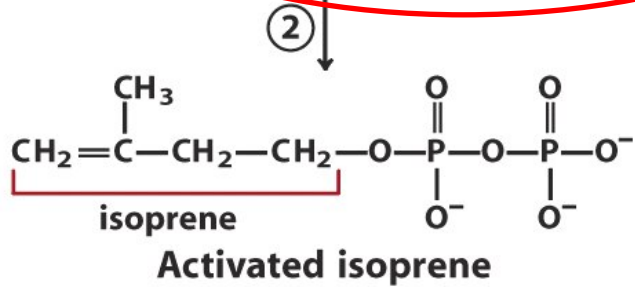
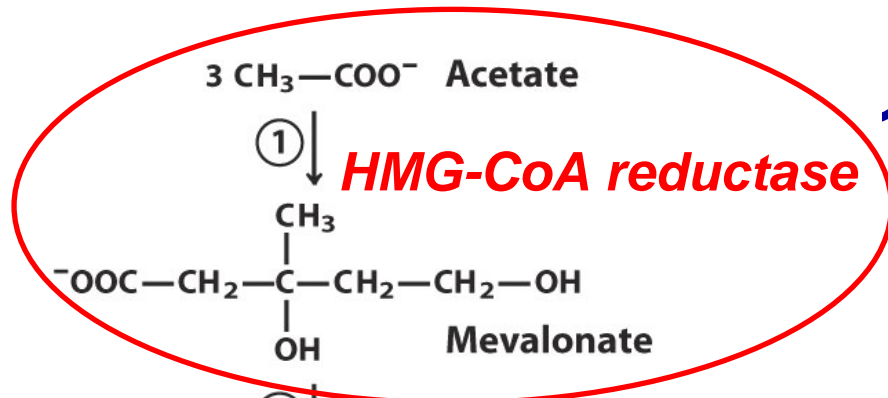

1. Condensation of 3 Ac-CoA to mevalonate
limiting step!!

2. Conversion of mevalonate to activated isoprene (3-isopentenyl pyrophosphate)

3. Condensation of 6 activated isoprene units to squalene

4. Cyclization

Regulation of HMG-CoA-reductase (integral membrane protein in ER)

1. **Feedback** – cholesterol stimulates proteolysis
2. **Hormonal** – inactivated by phosphorylation, activated by dephosphorylation
3. **Transcription** - via SREBP (rate of synthesis)
sterol regulatory element binding protein
4. **Therapeutics** - mevalonate analogs

competitive inhibitor – statins

lovastatin, atorvastatin - Lipitor

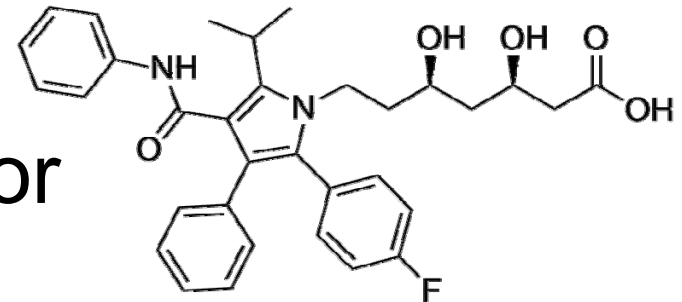

SREBP pathway = sterol regulatory binding element protein

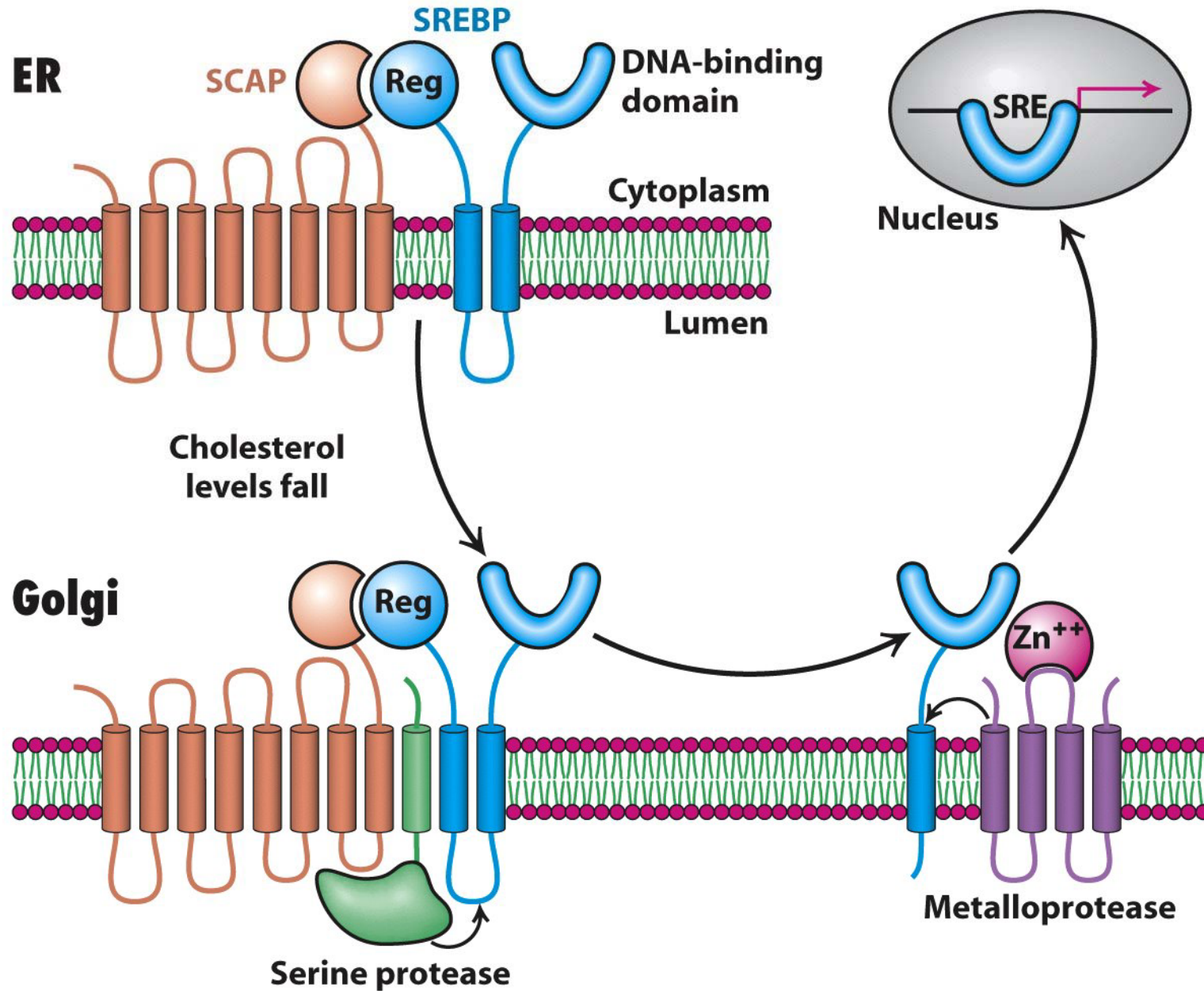

Cholesterol is a precursor to bilesalts (and to steroid hormones and vitamin D)

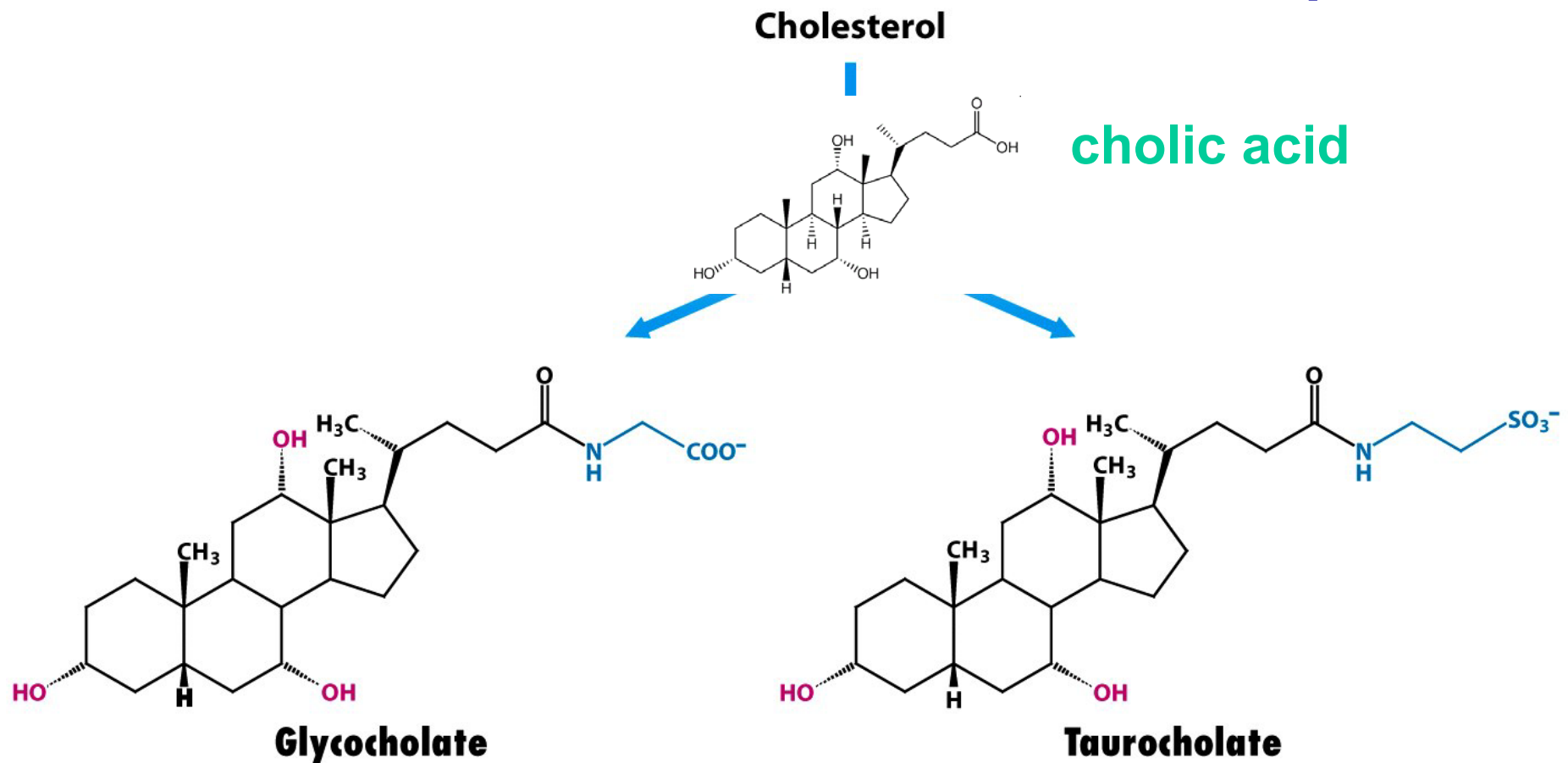

Enterohepatic circulation

circulation of bile from the liver, to the small intestine where it aids in fat digestion

hepatocytes metabolize cholesterol to lipid-soluble bile acids → bile salts

conjugated to glycine or taurine

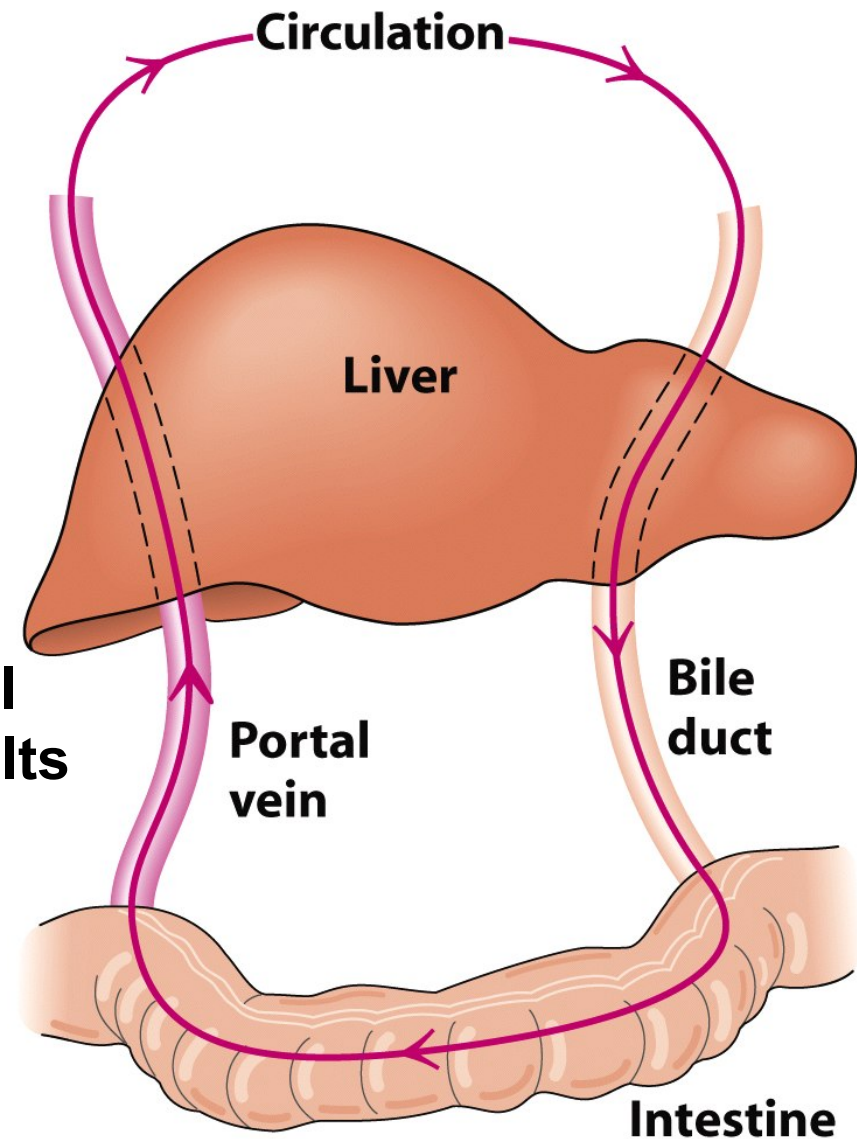
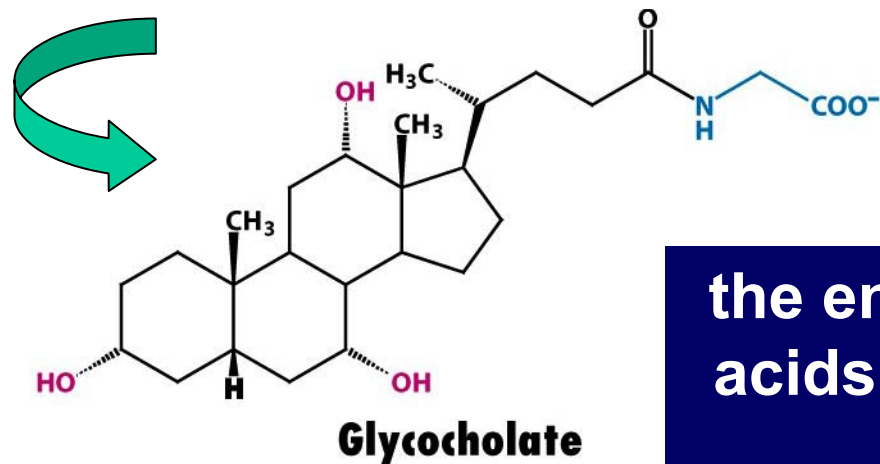

the enterohepatic circulation of bile acids may be disrupted as a way to lower cholesterol

Varying Lipid Class

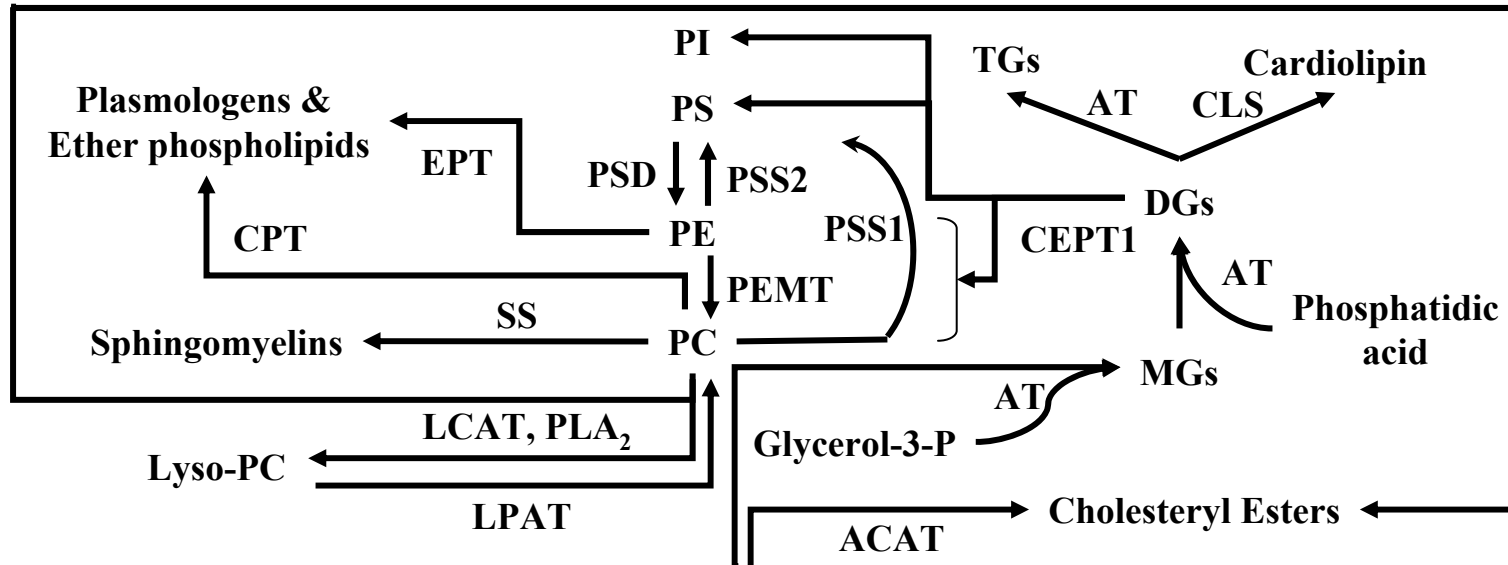

Free Fatty Acids

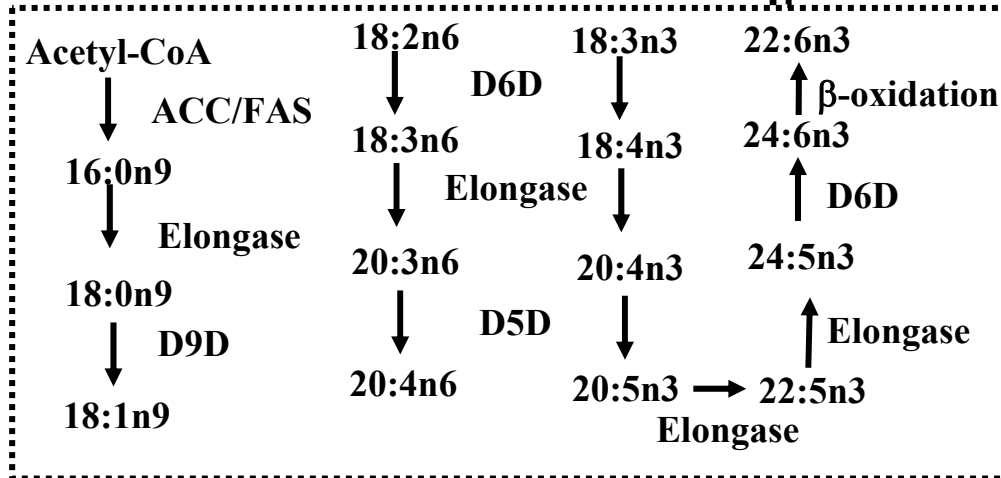

- EPT = ethanolamine-phosphotransferase
- CEPT1 = choline/EPT-1
- AT = acyltransferase
- LCAT = lecithin cholesterol AT
- ACAT = acyl coenzyme-A:cholesterol transferase
- LPAT = Lyso-PC AT
- PEMT = PE methyl transferase
- PSD = PS decarboxylase
- PSS = PS synthase
- CLS = cardiolipin synthase
- SS = sphingomelin synthase
- ACC/FAS=acetyl-CoA carboxylase
- FAS = fatty acid synthase

- PC = phosphatidyl choline
- PE = phosphatidyl ethanolamine
- PS = phosphatidyl serine
- PI = phosphatidyl inositol
- MGs = monoacylglycerols
- DGs = diacylglycerols
- TGs = triacylglycerols

What is a lipid?

Classical definition:

biological molecule that is soluble in organic solvent,
but insoluble in water

Modern (specific) definition:

fatty acids and their derivatives, and substances related
biosynthetically or functionally to these compounds

More specific definition:

Hydrophobic small molecules that originate by carbanion-
based condensations of thioesters (fatty acids, polyketides,
etc.) and/or by carbocation-based condensations of isoprene
units (prenols, sterols, etc)

Specific structural-based definition

Lipid Biosynthesis - summary

- **Lipids overview** classification, structure, synthesis
- **Fatty acids** in liver (fat) and cytosol; Mal-CoA; multifunctional enzyme; modified in ER
- **Eicosanoids** important signaling molecules; play roles in pain and inflammation
- **Triacylglycerols** in liver, fat, and intestine; energy storage; phosphatidate; dynamic equilibrium
- **Phospholipids** in almost all cells; phosphatidate, 2 strategies for synthesis, membrane components
- **Cholesterol** in all cells; mostly liver, 4 steps, from Ac-CoA via isoprene, HMG-CoA reductase
- **Bile acids** important in fat digestion, enterohepatic circulation

Whew.....



- <http://www.cyberlipid.org/>
- <http://www.lipidlibrary.co.uk/>
- <http://www.lipidmaps.org/>
- <http://www.metabolomics.se/>
 - (contains downloadable file of today's lecture under the section "Courses")

